

User's Manual

IP SERIAL SERVER

1-port
2-port
4-port

Release Version : 02
Release Date : 2005.4.26

Contents

1.	INTRODUCTION.....	7
1.1	Main Features	7
1.2	Communication Modes.....	8
1.2.1	Direct IP Mode	8
1.2.2	Virtual COM Mode	8
1.2.3	Paired Mode	8
1.2.4	Heart Beat.....	9
1.3	IP SERIAL SERVER Quick Start Guide.....	10
1.3.1	Hardware Setup	10
1.3.2	Software Installation.....	10
1.3.3	IP SERIAL SERVER Configuration.....	10
1.3.4	Install Virtual COM Ports on PC.....	11
1.3.5	Check Communications	12
2.	MAKING THE HARDWARE CONNECTIONS	13
2.1	Package Checklist	13
2.1.1	Indicator Lights	13
2.1.2	Ethernet Connector.....	13
2.1.3	Power Connector	13
2.1.4	Reset Button	14
2.1.5	DIP Switches	14
2.1.6	Serial Ports	15
2.2	IP SERIAL SERVER /Port Operational Modes	16
2.2.1	Default Mode.....	16
2.2.2	Console Mode.....	16
2.2.3	Upgrade Mode.....	16
2.2.4	RS-232 Mode	16
2.2.5	RS-422 Mode	16
2.2.6	RS-485 Mode	16
3.	INSTALLING THE IP SERIAL SERVER MANAGER SOFTWARE	18
3.1	Software Installation	18
3.1.1	Automatic Installation	18
3.1.2	Manual Installation.....	18
3.1.3	Updating an Existing Installation	20
3.1.4	Opening the IP SERIAL SERVER Manager	21
4.	USING IP SERIAL SERVER MANAGER.....	22
4.1	Hardware Setup.....	22
4.2	Software Setup.....	23

4.3	Software Overview	24
4.3.1	Menus	24
4.3.2	Server Icons Pane	25
4.3.3	IP SERIAL SERVER / Virtual COM Lists	26
4.3.4	Status Bar	26
4.4	Search for Servers	26
4.5	Configure Server Properties.....	27
5.	CONFIGURING THE IP SERIAL SERVER PROPERTIES.....	30
5.1	Description of the Server Properties	30
5.1.1	Server Name	30
5.1.2	Serial Number.....	30
5.1.3	Password.....	30
5.1.4	DHCP	30
5.1.5	IP Address	31
5.1.6	Netmask.....	31
5.1.7	Gateway.....	32
5.1.8	MAC Address.....	32
5.1.9	Version & Date.....	32
5.1.10	Link Status	32
5.1.11	Server Serial Port.....	32
5.1.12	Baud Rate.....	32
5.1.13	Data/Parity/Stop.....	32
5.1.14	Flow Control	32
5.1.15	TCP/UDP Protocol.....	32
5.1.16	Serial Timeout.....	33
5.1.17	TCP Alive Timeout.....	33
5.1.18	Connection Mode.....	33
5.1.19	Delimiter HEX 1 and Delimiter HEX 2	34
5.1.20	Force Transmit	34
5.1.21	Port Status	34
5.1.22	TCP/UDP Port.....	34
5.1.23	Serial Port Mode	34
5.1.24	Connection At	35
5.1.25	Max Connection.....	35
5.1.26	Remote IP Address.....	35
5.1.27	Update/Save	35
6.	INSTALLING VIRTUAL COM PORTS	38
6.1	Virtual COM Port Installation	38
6.2	Matching the IP SERIAL SERVER and Virtual COM Port Settings.....	40
7.	REMOVING VIRTUAL COM PORTS	43

7.1	Removing the Virtual COM port with IP SERIAL SERVER Manager	43
7.2	Removing the Virtual COM Port using Device Manager.....	43
8.	UPGRADING THE IP SERIAL SERVER FIRMWARE.....	45
8.1	Downloading the Firmware	45
8.2	Upgrading Via IP SERIAL SERVER Manager.....	45
8.2.1	Preparing the Software	45
8.2.2	Upgrading the Firmware	45
9.	USING CONSOLE MODE	47
9.1	Console Mode Setup.....	47
9.1.1	Navigating the Configuration Menus	48
9.1.2	Using a Password	48
10.	USING THE WEB SERVER	49
10.1	Setting Server Properties	49
11.	USING TELNET	52
11.1	Configuration Using Telnet	52
11.1.1	Navigating the Configuration Menu	53
12.	TECHNICAL DATA	54
12.1	IP Serial Server Feature List.....	54
12.2	Default Settings.....	56
13.	IP SERIAL SERVER LCD PANEL CONFIGURATION	57
13.1	Basic Operations of the Buttons	57
APPENDIX A: RS-232 CONNECTIONS		60
	Serial Server DB-9 Pin-outs in RS-232 Mode	60
APPENDIX B: RS-422 CONNECTIONS		60
	Serial Server DB-9 Pin-outs in RS-422 Mode	60
APPENDIX C: RS-485 CONNECTIONS		61
	Serial Server DB-9 Pin-out in RS-485 Mode	61
APPENDIX D: NETWORK CONNECTIONS		62
	Standard Ethernet Cable RJ-45 Pin-out.....	62
	Crossover Ethernet Cable RJ-45 Pin-out.....	62

Figures

Figure 1	Typical Hardware Setup.....	10
Figure 2	The Server Properties Window	11
Figure 3	Configuring the Virtual COM Port	12
Figure 4	Top View of the IP SERIAL SERVER (dip switch for 1/2-port model only).....	14
Figure 5	The Console Mode (Server) Screen in the HyperTerminal Window	15
Figure 6	The IP SERIAL SERVER Serial Port Connector (1-port model).....	15
Figure 7	The IP SERIAL SERVER Serial Port Connector (2-port model).....	15
Figure 8	The IP SERIAL SERVER Serial Port Connector (4-port model).....	15
Figure 9	Internal Setting to Select RS-485 Bias (1-port model)	17
Figure 10	Internal Setting to Select RS-485 Bias (2-port model)	17
Figure 11	Internal Setting to Select RS-485 Bias (4-port model)	17
Figure 12	The Run Dialogue Box.....	18
Figure 13	The Install Shield Wizard Window.....	18
Figure 14	IP SERIAL SERVER Manager Setup Window	19
Figure 15	The Choose Destination Window	19
Figure 16	The Install Shield Wizard Complete Window	20
Figure 17	The InstallShield Wizard Modify, Repair or Remove Screen.....	20
Figure 18	IP SERIAL SERVER Manager Displaying all IP SERIAL SERVER DEVICES	21
Figure 19	Ethernet Connection via a LAN	22
Figure 20	Direct Ethernet Connection using a Crossover Cable.....	23
Figure 21	The IP SERIAL SERVER Manager Window.....	24
Figure 22	The Search Setup Window.....	27
Figure 23	The Server Properties Window	28
Figure 24	The Restart Dialogue Box.....	28
Figure 25	The Restarting Dialogue Box.....	28
Figure 26	The Server Search Dialogue Box.....	29
Figure 27	The Search IP SERIAL SERVER Manager Dialogue Box	29
Figure 28	IP SERIAL SERVER Manager Server Properties Window	30
Figure 29	Pinging using the DOS command window	31
Figure 30	The Server UDP Configuration Screen.....	33
Figure 31	The Restart Dialogue Box.....	36
Figure 32	The Web Server Page.....	37
Figure 33	The Search Setup Window.....	38
Figure 34	The Found Server Window	39
Figure 35	The COMInst Window.....	39
Figure 36	The Control Panel Window.....	40
Figure 37	The Device Manager Window	41

Figure 38	Virtual Com Port Properties Window	42
Figure 39	The IP SERIAL SERVER Manager Window.....	43
Figure 40	Confirm Device Removal	44
Figure 41	Saving and Restarting the Configuration	48
Figure 42	The Web Server Page.....	49
Figure 43	The Web Server Serial Port Properties Page.....	50
Figure 44	The Web Server Operation Page.....	51
Figure 45	Telnet Configuration Screens.....	53
Figure 46	Saving and Restarting the Configuration	53
Figure 47	The Tree Structure of LCD Menu.....	59
Figure 48	RS-232 Connections in a DB-9 Connector	60
Figure 49	RS-422 Connections in a DB-9 Connector	60
Figure 50	DB-9 Pin-out in RS-485 Mode	61
Figure 51	2-wire RS-485 Connection.....	61
Figure 52	Pin-out for a Standard Ethernet Cable	62
Figure 53	Pin-out for a Crossover Ethernet Cable	62

1. INTRODUCTION

The **IP SERIAL SERVER** provides the serial device server for Windows hosts to control serial devices located virtually anywhere through a TCP/IP or UDP/IP Ethernet connection. The **IP SERIAL SERVER** has the asynchronous serial port connection on one side, and a 10/100 Mbps Ethernet connection on the other side. It connects devices, such as CNC, weight scales, and scanners. Applications include industrial/factory automation, automatic warehouse control, and hospital/laboratory automation.

The **IP SERIAL SERVER** Windows driver is designed to control the **IP SERIAL SERVER** Ethernet devices. The driver installs a virtual COM on windows which maps the virtual COM port to the IP address of the **IP SERIAL SERVER** device across the network, enabling the Windows applications to access remote serial devices over Ethernet.

IP SERIAL SERVER can function as a server or client for both TCP and UDP connection. The application scenarios are direct IP mode, virtual COM mode, and paired mode. In direct IP and virtual COM modes, **IP SERIAL SERVER** should only work as a server. When in the paired mode one **IP SERIAL SERVER** must set as a client and the other must set as a server in both TCP and UDP connection.

1.1 Main Features

- **Multi-interface serial ports**

IP SERIAL SERVER and software selectable for RS-232, RS-422, or RS-485 interface.

Note 1: there are two kinds of 1-port models; one supports RS-232, RS-422, RS-485; and the other one only supports RS-232 mode.

Note 2: there are two kinds of 2-port models; one model's port 1 supports RS-232, RS-422, RS-485; and the other one's port 1 only supports RS-232 mode.

DIP Switch selectable for Console Mode (For 1-port and 2-port models only)

- **10/100 Mbps Ethernet** with Auto-detecting
- **TCP or UDP / Client or Server operation** - configurable
- **Software OS Support** - Windows XP/2000/NT/98/ME
- **Firmware Upload** for future revisions/upgrades
- **Configuration** of Ethernet and serial port settings can be accomplished using any of four methods:

IP SERIAL SERVER Manager Software for Windows allows configuration via a network connection or directly from the Ethernet port of a computer (using an Ethernet crossover cable).

Web Server allows configuration via the network using any web browser.

Telnet allows configuration via the network by accessing the setup configuration menu.

Console Mode allows configuration through an RS-232 serial port in using a VT100 Terminal Emulation program and an RS-232 crossover cable.

- **Virtual COM Driver Software for Windows** - installs virtual COM ports, viewable in the Windows Device Manager under **Ports (COM & LPT)**. Virtual COM port provides access to any of the ports on the **IP SERIAL SERVER** and, like any other serial port (legacy, PCI, USB or PCMCIA) on the computer. Any program running on the computer and using Windows-based COM ports can access the serial devices attached to the **IP SERIAL SERVER**. The LAN becomes transparent to the serial device and the software running on the PC.
- **Heart Beat Connection** - selectable protocol ensures reliable communications in Virtual COM Port or Paired Connection modes. This feature restores the connections if communications are temporarily lost at either end due to loss of power or the Ethernet connection.

1.2 Communication Modes

The **IP SERIAL SERVER** enables communication with serial devices over a LAN or WAN. Serial devices no longer are limited to a physical connection to the PC COM port. They can be installed anywhere on the LAN using TCP/IP or UDP/IP communications. This allows traditional Windows PC software access to serial devices anywhere on the LAN/WAN network.

1.2.1 Direct IP Mode

Direct IP connections allow applications using TCP/IP or UDP/IP socket programs to communicate with the asynchronous serial ports on the **IP SERIAL SERVER**. In this type of application the **IP SERIAL SERVER** is configured as a TCP or UDP server. The socket program running on the PC establishes a communication connection with the **IP SERIAL SERVER**. The data is sent directly to and from the serial port on the server. When using UDP protocol the server can be configured to broadcast data to and receive data from multiple IP addresses.

1.2.2 Virtual COM Mode

Install Virtual COM Mode allows the user to add a driver, to provide a virtual COM port on the computer. The new COM port shows up in the Device Manager. Windows programs using standard Windows API calls are able to interface to virtual COM ports. When a program on the PC opens the new COM port, it communicates with the remote serial device connected to one of the ports on the **IP SERIAL SERVER**. After connection, the LAN is transparent to the program and serial device. Applications are able to work just as if the serial device is connected directly to a physical COM port on the computer. The virtual COM port software converts the application's data into IP packets, sends it across the network to the **IP SERIAL SERVER**, which converts the IP packet back to serial data and sends the data out a serial port located on the **IP SERIAL SERVER**.

To use this mode, the **IP SERIAL SERVER** must be set to either TCP/server or UDP/server with a designated communication port number. The virtual COM driver is the TCP or UDP client.

1.2.3 Paired Mode

Paired Mode is also called *serial tunneling*. In this mode any two serial devices that can communicate with

a serial link will be able to communicate using two **IP SERIAL SERVER's** and the LAN.

Two **IP SERIAL SERVER's** are connected to a network, one configured as a TCP or UDP client and the other as a TCP/UDP server. When setting up the server the remote IP address section must contain the address of the client. This will allow the client's IP address to pass the IP address-filtering feature of the server. Conversely, the Remote IP address of the client must contain the server's IP address. Both communication port numbers must be the same.

1.2.4 Heart Beat

The **Heart Beat** protocol connection provides a reliable communications connection in **Virtual COM Port Mode** or with **Paired Connection Mode**. This feature restores the connection if communications are temporarily lost at either end due to loss of power or Ethernet connection.

Without this feature a device that loses a connection and stops communicating would not be able to reconnect without human intervention. A TCP data connection can be lost when there is a power failure or temporary loss of an Ethernet connection on either the client or server. If a loss occurs the Heart Beat feature will try to reconnect the TCP data connection every five seconds until communications is established again. The Heart Beat feature is available for use in **Virtual COM Port Mode** and **Paired Connection Mode**. This is not available when using a UDP application.

1.3 IP SERIAL SERVER Quick Start Guide

For descriptive purposes this Quick Start Guide considers a typical configuration consisting of a **PC** connected via an Ethernet LAN to an **IP SERIAL SERVER** connected to the RS-232 port of a **serial device**.

1.3.1 Hardware Setup

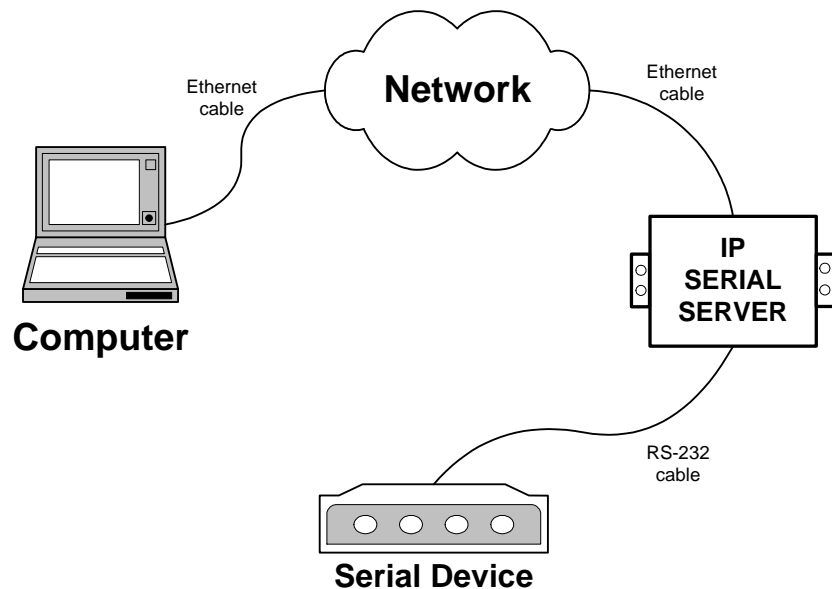

Figure 1 Typical Hardware Setup

Step 1: Connect the **IP SERIAL SERVER** to the network using a standard network cable.

Step 2: Connect the **IP SERIAL SERVER** to the RS-232 port on the **serial device**.

Note:

If the serial device is configured as a DCE use a straight-through serial cable. If the serial device is configured as a DTE use a crossover (null modem) cable.

Step 3: Set all the DIP switches to the **OFF** position.

Step 4: Apply power to the **IP SERIAL SERVER**.

1.3.2 Software Installation

Using the CD included with the **IP SERIAL SERVER**, install the **IP SERIAL SERVER Manager** software on the configuring computer.

1.3.3 IP SERIAL SERVER Configuration

Step 1: Open the **IP SERIAL SERVER Manager** software. It will automatically search for any reachable **IP SERIAL SERVER DEVICES**. A list of all **IP SERIAL SERVER** connected to the LAN will appear in the **IP SERIAL SERVER List** window.

Step 2: Double click the desired **IP SERIAL SERVER** port on the list to bring up the **Server Properties** configuration screen.

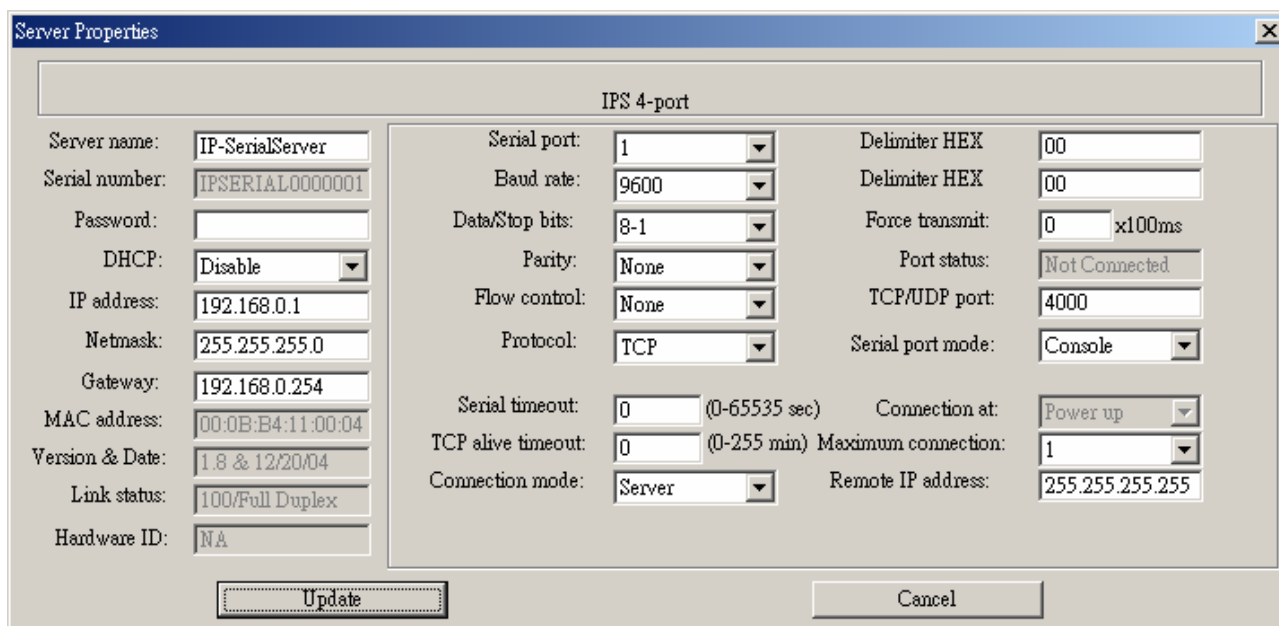

Figure 2 The Server Properties Window

Step 3: Change the **Server Properties** as required.

Enable **DHCP** to allow the **IP SERIAL SERVER** to generate its own IP address

OR

Obtain appropriate static **IP**, **Netmask** and **Gateway** addresses from your Network Administrator (**recommended**)

Set the **Serial Port Mode** property to RS-232 to match the serial device connected to the **IP SERIAL SERVER**.

Set **Baud Rate**, **Data/Parity/Stop**, and **Flow Control** to match the configuration of the serial device connected to the **IP SERIAL SERVER** port

Step 4: When the parameters have been set, click **Update**. Following the prompts in the dialogue boxes, **Restart** the **IP SERIAL SERVER** and **Search all reachable servers** again.

Step 5: Re-enter **Server Properties** to verify the changes have taken effect, or to view/change the configuration of other ports. Each port must be configured separately.

1.3.4 Install Virtual COM Ports on PC

Step 1: From the **Windows Start** menu, run the **Install Virtual COM Ports** utility included with the **IP SERIAL SERVER Manager** software,

Step 2: Search for all servers on the network

Step 3: Select a port and map it to an unused COM port (e.g. Port 3). Configure it for TCP protocol and the appropriate IP address (determined in the last section).

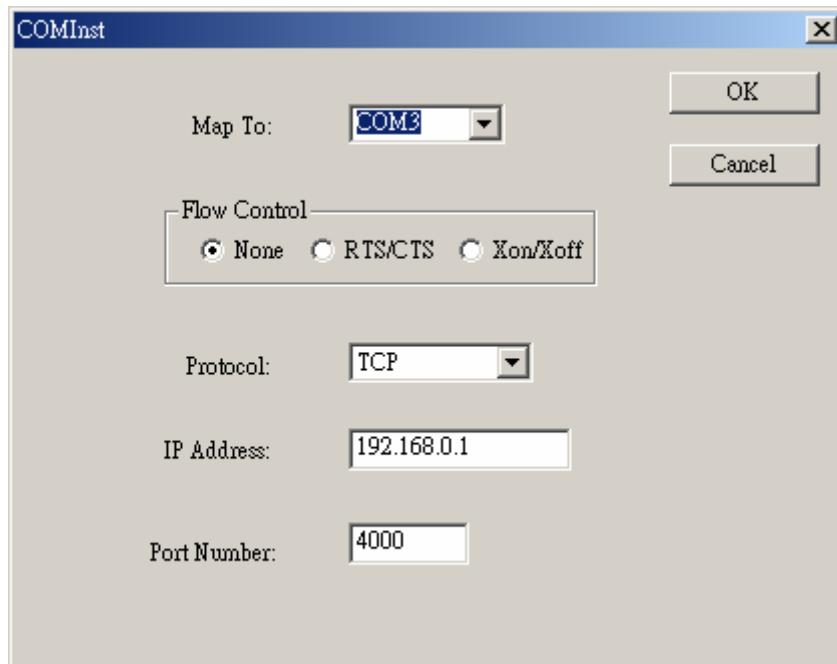

Figure 3 Configuring the Virtual COM Port

1.3.5 Check Communications

Step 1: From the **Windows Start** menu, run **HyperTerminal**

Step 2: Configure **HyperTerminal** to connect using the COM port configured in the last section (e.g. Port 3).

Step 3: Set **Baud Rate**, **Data/Parity/Stop**, and **Flow Control** to match the configuration of the serial device connected to the **IP SERIAL SERVER** serial port.

Step 4: Communications with the serial device should now be operational.

2. MAKING THE HARDWARE CONNECTIONS

2.1 Package Checklist

The **IP SERIAL SERVER** is shipped with the following items included:

- ✓ IP SERIAL SERVER
- ✓ Power Adapter (optional)
- ✓ This Operation Manual
- ✓ CD-ROM disc with manual, IP SERIAL SERVER Manager and Virtual COM Driver software for Windows 98/ME/2000/XP/NT 4.0

2.1.1 Indicator Lights

Light	Indication
Power	Red - power is applied
Link	Yellow – 10BaseT Ethernet connection established Green – 100BaseTX Ethernet connection established
Ready	Flashing Green – system is ready
Serial (4)	When set up as a TCP server: Steady Green - client has made a connection, communications starting Flashing Green – data present at serial port Light off – connection closed When setup in UDP mode: Steady Green (all ports) Flashing Green – data is being transmitted

2.1.2 Ethernet Connector

The **IP SERIAL SERVER** has a standard RJ-45 receptacle mounted in the top edge of the chassis. The **IP SERIAL SERVER** can be connected to an Ethernet hub, switch, or wall plate using a standard straight-through RJ-45 (male) Ethernet cable. To connect directly to an RJ45 Ethernet port on a PC or laptop a crossover Ethernet cable must be used.

Note:

Refer to Appendix D for details on Network Cables

2.1.3 Power Connector

Plug the ultra-miniature 2.5mm phone plug from the included power supply into the power jack and then plug the supply in. When power is applied the Red power light will illuminate. The tip of the power plug is positive; the sleeve is negative.

2.1.4 Reset Button

This switch resets the unit, similar to the effect of removing/applying power. The Reset switch is recessed to avoid accidental operation. To reset the unit, insert a small plastic tool, press lightly and hold for three seconds. The Link and Ready lights will go out and then come back on.

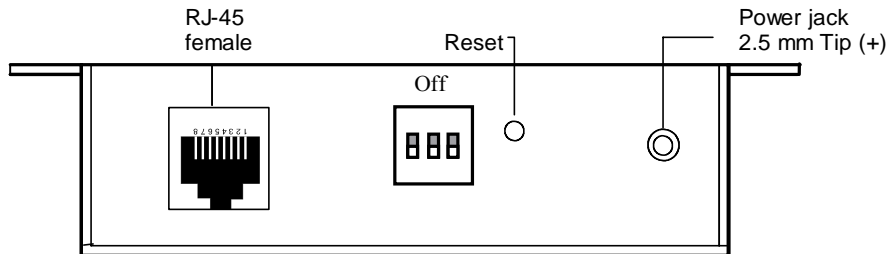

Figure 4 Top View of the IP SERIAL SERVER (dip switch for 1/2-port model only)

2.1.5 DIP Switches

A triple DIP (dual inline package) switch allows the **IP SERIAL SERVER** to be placed into **Console Mode**. When all three switches are moved into the ON position the **IP SERIAL SERVER** enters **Console Mode**, allowing configuration of the **IP SERIAL SERVER** (using an RS-232 connection through the serial port on the IP SERIAL SERVER) from a PC running a terminal program such as **HyperTerminal**. When the **IP SERIAL SERVER** enters **Console Mode** the **Console Mode** screen will appear in the HyperTerminal program window. The serial port settings must be 8-N-1 at 9600 baud.

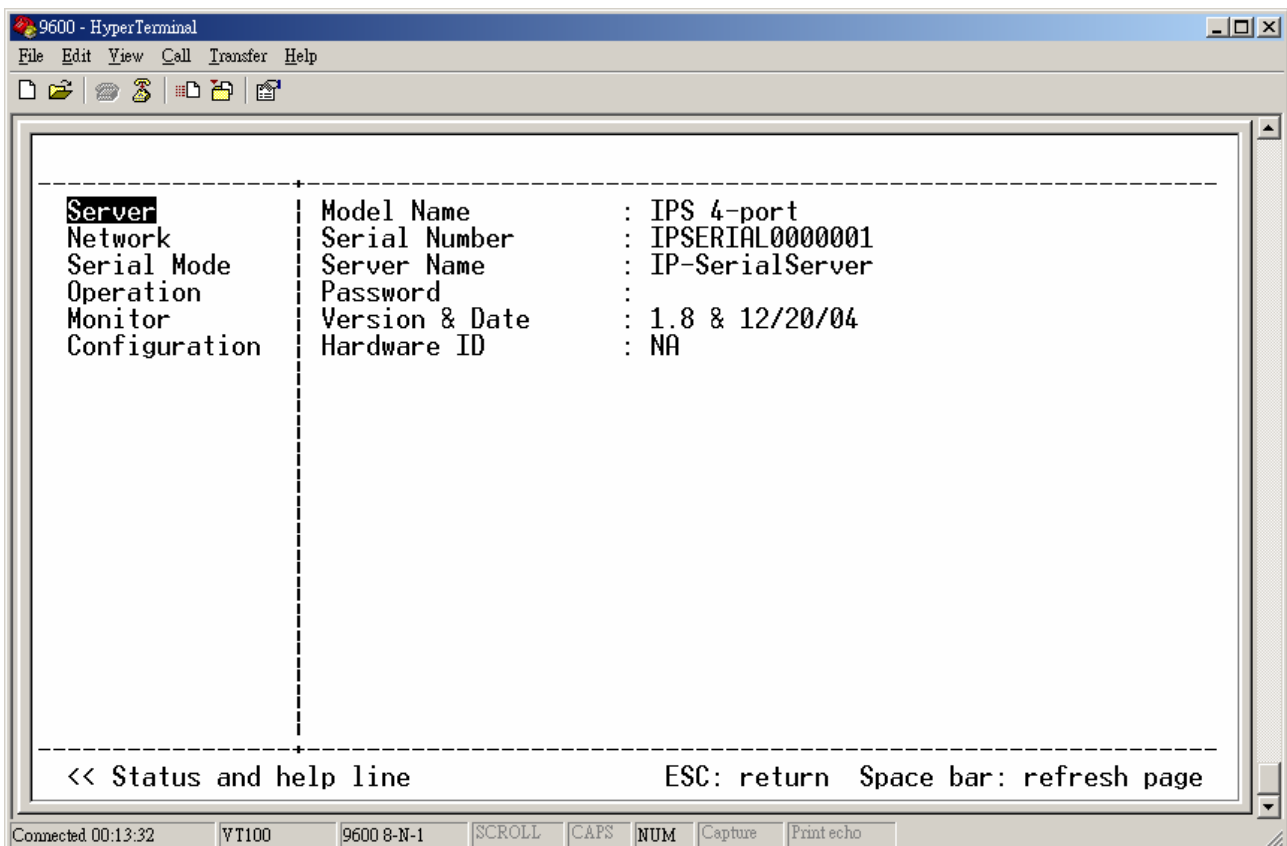

Figure 5 The Console Mode (Server) Screen in the HyperTerminal Window

When any of the DIP switches are switched back to the OFF position, the **IP SERIAL SERVER** will revert to the mode it was in before **Console Mode**.

Note:

The **IP SERIAL SERVER** can be put into Console mode using either of two methods:

1. Switching all the DIP switches to the ON position
2. With any DIP switch in the OFF position set the Server Properties Console Mode field to Console and Update/Save the configuration

2.1.6 Serial Ports

The **IP SERIAL SERVER** has one serial port. The port can be configured as a **Console Mode** connection or as an RS-232, RS-422 or RS-485 interface to the **IP SERIAL SERVER** (if any of the DIP switches are in the OFF position) using the **IP SERIAL SERVER Manager** software, via **Telnet**, or using the **Web Server**.

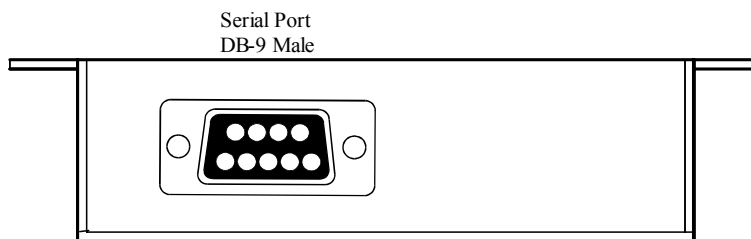

Figure 6 The **IP SERIAL SERVER** Serial Port Connector (1-port model)

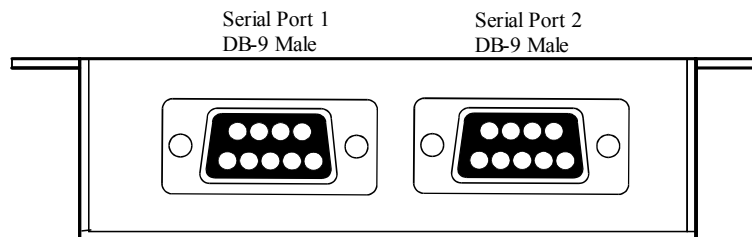

Figure 7 The **IP SERIAL SERVER** Serial Port Connector (2-port model)

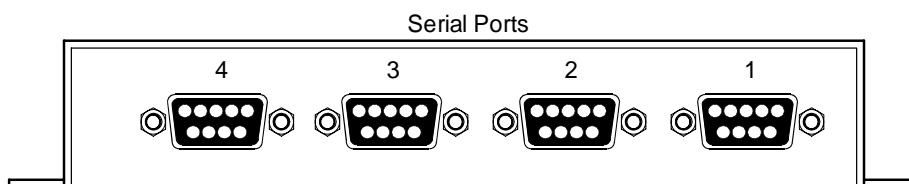

Figure 8 The **IP SERIAL SERVER** Serial Port Connector (4-port model)

2.2 IP SERIAL SERVER /Port Operational Modes

Using the **IP SERIAL SERVER Manager** the **IP SERIAL SERVER** can be put into **Console Mode**, **Default Mode** or **Upgrade Mode**. The serial ports can be configured for RS-232, RS-422 or RS-485 operation. The server also can be put into **Console Mode** by placing all the DIP switches into the ON position.

2.2.1 Default Mode

When **Default Mode** is selected and the server properties are **Updated (Saved)** all the configuration settings return to their default values.

2.2.2 Console Mode

In **Console Mode** the **Configuration Menu** can be accessed from a PC by connecting its RS-232 serial port to the **IP SERIAL SERVER** serial port or Serial Port 1. Since the computer is a DTE device, and the serial ports are configured as DTEs (with DB-9M connectors), a null modem crossover cable must be used.

In **Console Mode** the default serial port settings are: **9600 baud**, **8 data bits**, **No parity**, and **1 stop bit**. From Windows, HyperTerminal with VT100 terminal emulation can be used for **Console Mode** configuration.

2.2.3 Upgrade Mode

In **Upgrade Mode** firmware can be uploaded from a PC via its serial port to the **IP SERIAL SERVER** serial port or Serial Port 1. Upgrading also can be accomplished via the network connection, using the **IP SERIAL SERVER Manager** software and a virtual COM port.

2.2.4 RS-232 Mode

In **RS-232 Mode** the currently selected serial port is configured as an RS-232 interface supporting eight RS-232 signal lines plus Signal Ground and is configured as a DTE, like a computer. Signals are single ended and referenced to Ground. To use handshaking, Flow Control must be set to RTS/CTS during Configuration.

2.2.5 RS-422 Mode

In **RS-422 Mode** the currently selected serial port is configured as an RS-422 interface supporting four RS-422 signal channels with full duplex operation for **Receive**, **Transmit**, **RTS** (Request To Send) and **CTS** (Clear To Send). The data lines are differential pairs (A & B) in which the B line is positive relative to the A line in the idle (mark) state. Ground provides a common mode reference. To use handshaking, Flow Control must be set to RTS/CTS during configuration.

2.2.6 RS-485 Mode

In **RS-485 Mode** the currently selected port is configured as an RS-485 interface supporting transmit (TX) and receive (RX) signal channels using 2-wire, half-duplex operation. The data lines are differential with the Data B line positive relative to Data A in the idle (mark) state. Ground provides a common mode reference.

RS-485 Receiver Biasing

RS-485 Receiver Biasing can be implemented from the **IP SERIAL SERVER** if the network does not supply it. Remove the two side-cover screws of the **IP SERIAL SERVER**, slide the cover off and re-position the bias jumpers (shown open in the figure below) to enable biasing (shorting).

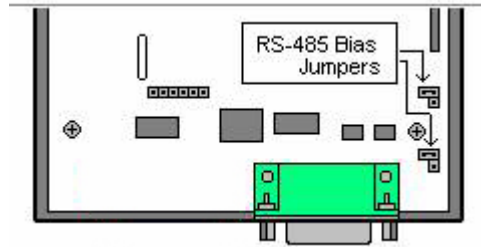

Figure 9 Internal Setting to Select RS-485 Bias (1-port model)

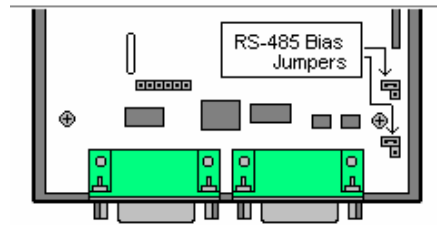

Figure 10 Internal Setting to Select RS-485 Bias (2-port model)

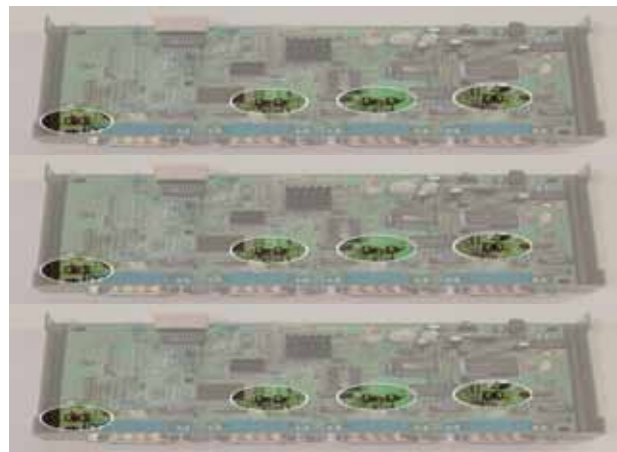

Figure 11 Internal Setting to Select RS-485 Bias (4-port model)

3. INSTALLING THE IP SERIAL SERVER MANAGER SOFTWARE

The Windows-based **IP SERIAL SERVER Manager** and **Virtual COM Port** software makes configuration fast and easy. If using Windows, installing the **IP SERIAL SERVER Manager** software and setting up virtual COM ports to configure the **IP SERIAL SERVER** is recommended.

3.1 Software Installation

The **IP SERIAL SERVER Manager** software includes:

- **IP SERIAL SERVER Manager**
- **Install Virtual COM Ports**
- **Uninstall Virtual COM Ports**

3.1.1 Automatic Installation

Step 1a: Inserting the CD in the CD-ROM should automatically launch the Install Shield Wizard.

3.1.2 Manual Installation

Step 1b: To manually start the software installation, from the **Windows Desktop**, click **Start** button.

At the **Run** command line type **D:start.exe** then click **OK**. (**D:** is the drive letter for the CD ROM.)

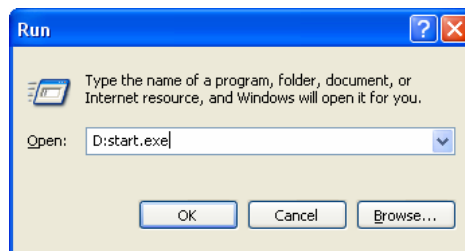

Figure 12 The Run Dialogue Box

The **Install Shield Wizard** window will be displayed.

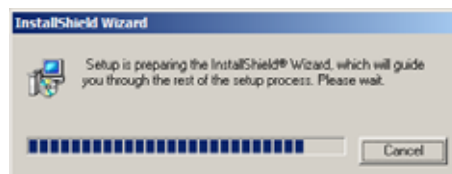

Figure 13 The Install Shield Wizard Window

Step 2: When the **IP SERIAL SERVER Manager Setup** window appears, click **Next**.

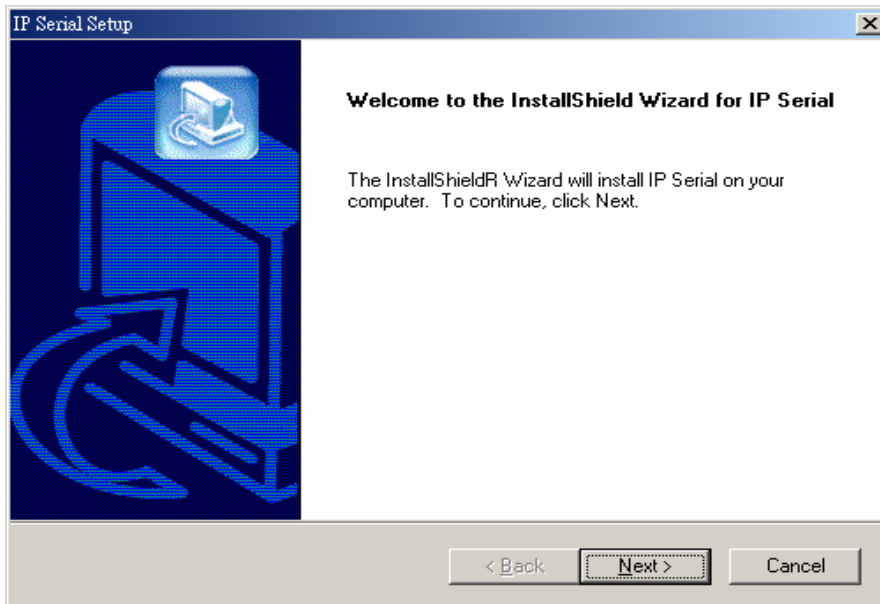

Figure 14 IP SERIAL SERVER Manager Setup Window

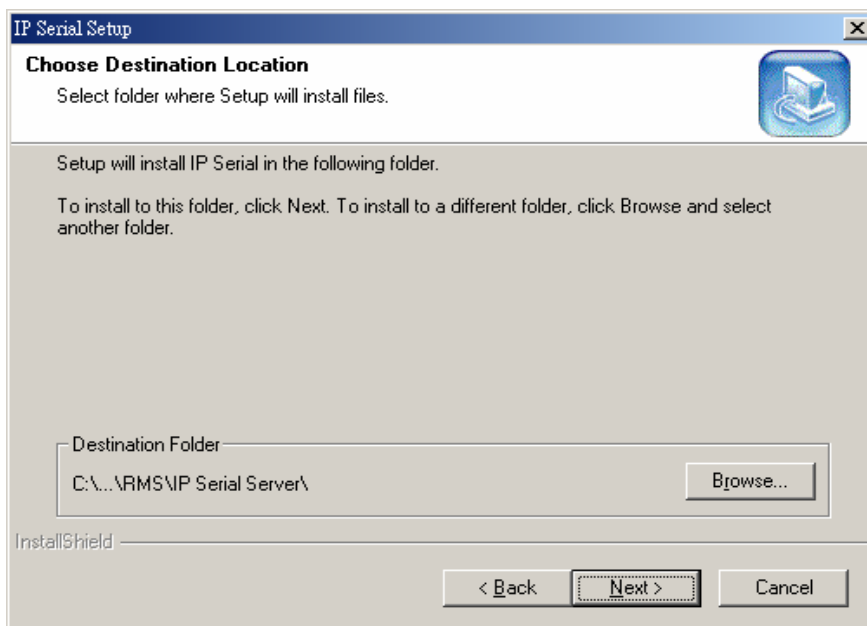

Figure 15 The Choose Destination Window

Step 3: When **Choose Destination Location** appears, click **Next**.

The installation progress will be shown until complete.

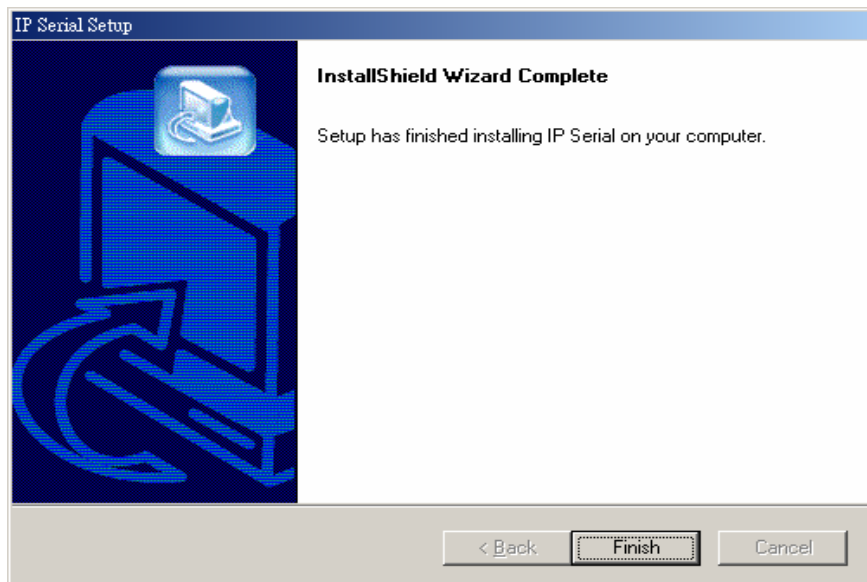

Figure 16 The Install Shield Wizard Complete Window

Step 4: Click **Finish** when the **Install Shield Wizard Complete** dialogue appears. When finished, dialogue box will close.

3.1.3 Updating an Existing Installation

If an older version of the **IP SERIAL SERVER Manager** software is already installed, the **Modify, repair or remove the program** window will appear when the installation process is initiated:

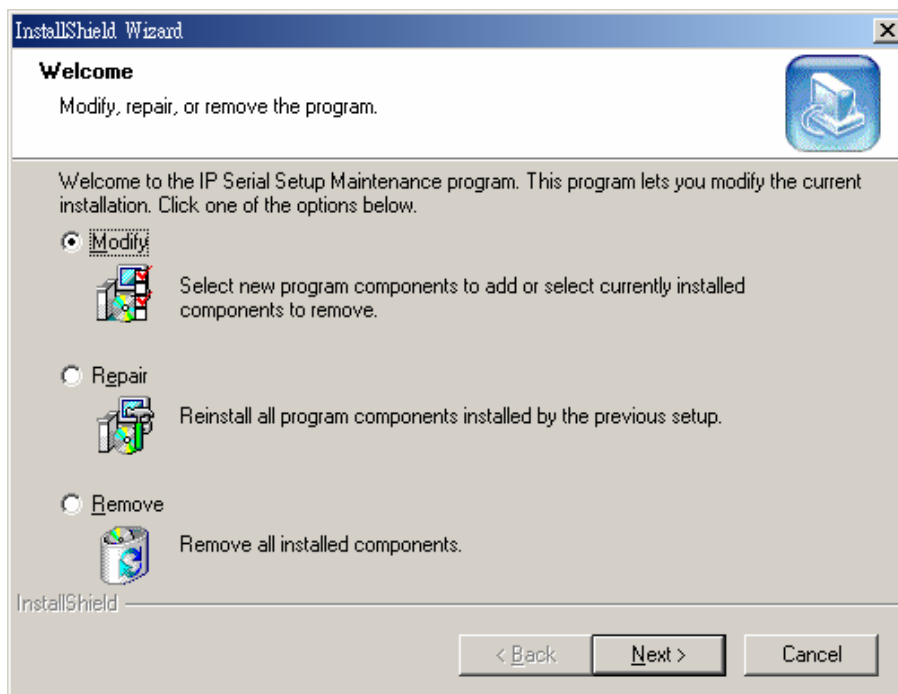

Figure 17 The InstallShield Wizard Modify, Repair or Remove Screen

The recommended procedure is to **Remove all installed components** first. Once the software has been removed, **Install** the new software.

3.1.4 Opening the IP SERIAL SERVER Manager

Step 5: If the **IP SERIAL SERVER** is not already connected to the network or to the Ethernet port on the computer, connect it. Set all the DIP switches to the OFF position. Apply power.

The **Power** indicator should light red, the **Link** light should indicate which type of Ethernet connection has been made and the **Ready** LED will flash indicating configuration can begin.

Step 6: Start the **IP SERIAL SERVER Manager** software. In Windows Desktop, click:

Start → Programs → Remote Management System → RMS → IP Serial Server → IP Serial Manager.

As soon as the **IP SERIAL SERVER Manager** opens it will initiate **Searching Server** and after a few seconds the **IP SERIAL SERVER List** will display all **IP SERIAL SERVER DEVICES** on the network.

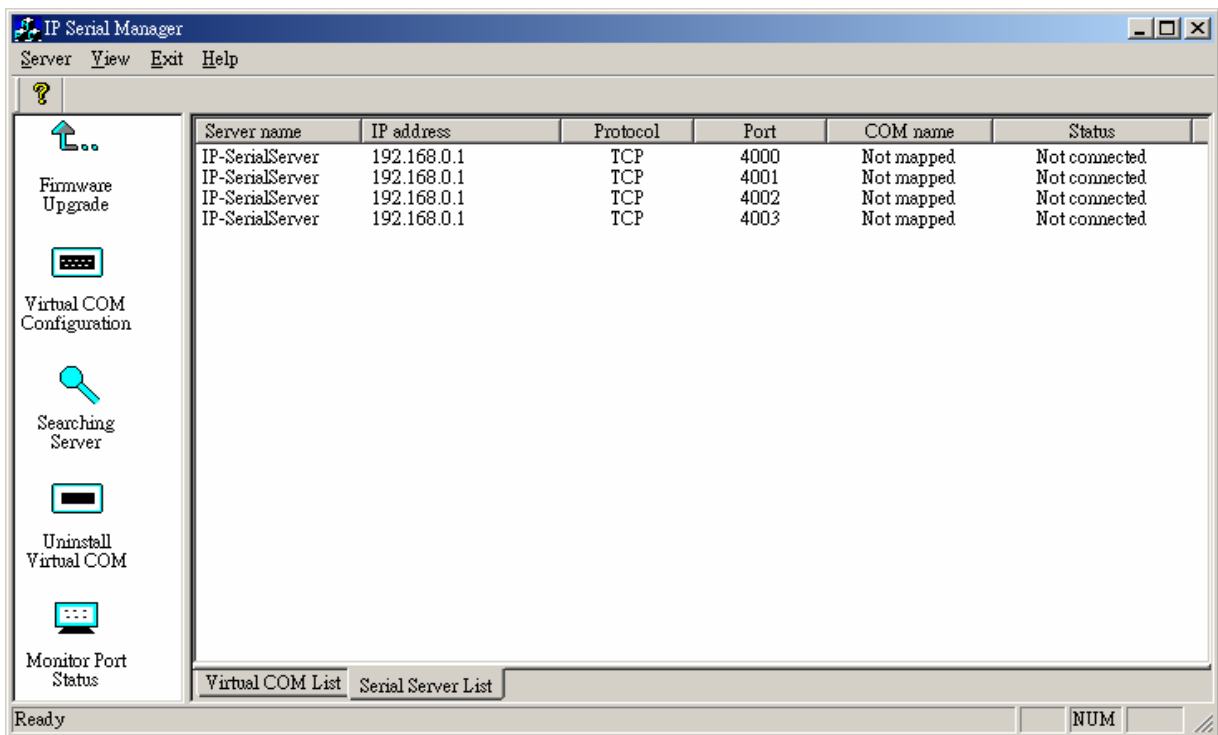

Figure 18 IP SERIAL SERVER Manager Displaying all IP SERIAL SERVER DEVICES

4. USING IP SERIAL SERVER MANAGER

The **IP SERIAL SERVER Manager** software allows:

- Searching for servers connected to the network
- Displaying and changing the configuration of those servers
- Installing virtual COM ports on a computer
- Displaying and configuring virtual COM ports
- Uninstalling virtual COM ports on a computer
- Upgrading the **IP SERIAL SERVER** firmware
- Monitoring Port Status
- Saving and Loading Configuration Files

4.1 Hardware Setup

Step 1: Connect the **IP SERIAL SERVER** to the LAN or to a computer Ethernet port. Set all the DIP switches on the **IP SERIAL SERVER** to the OFF position

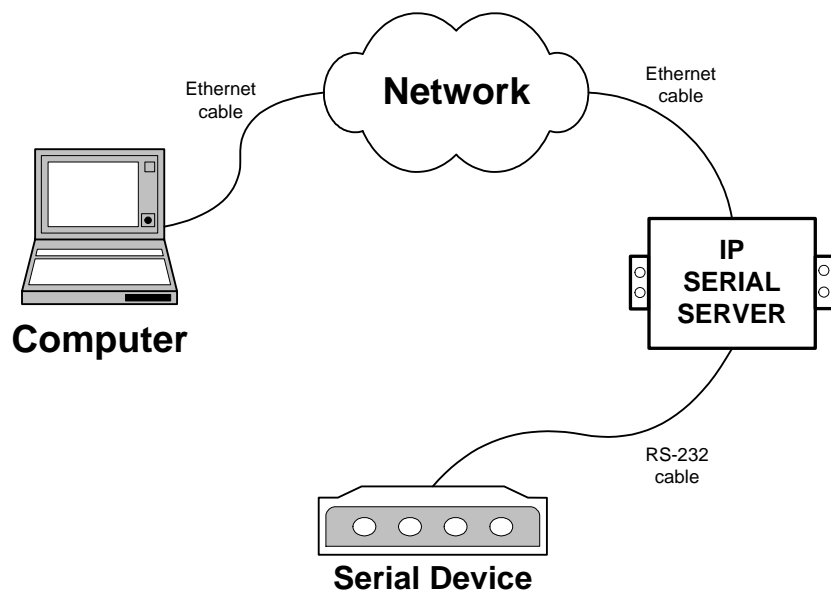

Figure 19 Ethernet Connection via a LAN

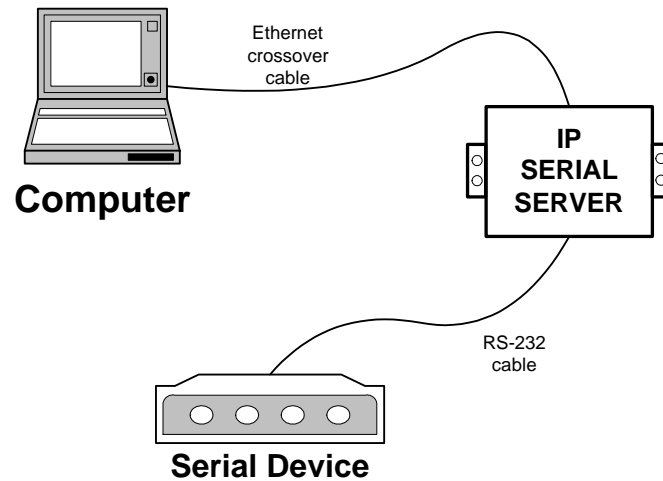

Figure 20 Direct Ethernet Connection using a Crossover Cable

Step 2: Apply power. The red Power indicator will light, the Link indicator lights when an Ethernet connection is made, and the Ready indicator will flash.

4.2 Software Setup

Step 3. To run the **IP SERIAL SERVER Manager**, from the **Windows Desktop** click:

Start → Programs → Remote Management System → RMS → IP Serial Server → IP SERIAL Manager.

As soon as the **IP SERIAL SERVER Manager** opens it will initiate **Searching Server** and after a few seconds the **IP SERIAL SERVER List** will display all **IP SERIAL SERVER DEVICES** on the network.

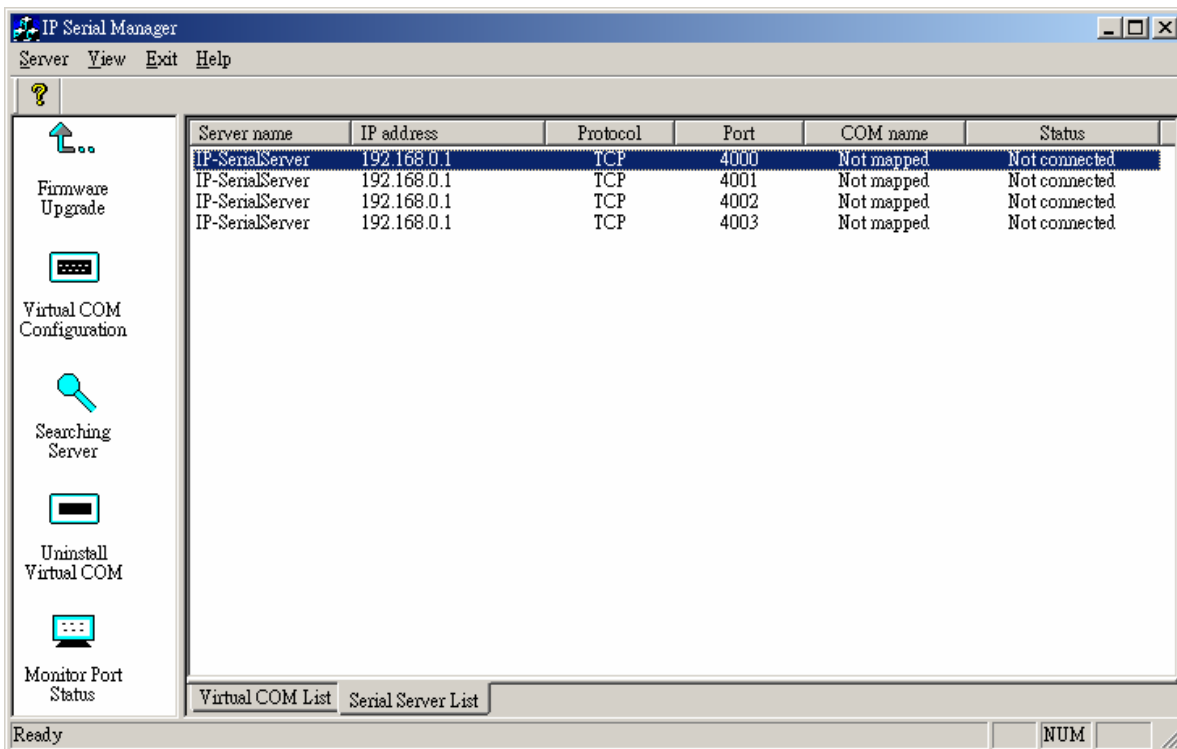

Figure 21 The IP SERIAL SERVER Manager Window

4.3 Software Overview

The IP SERIAL SERVER Manager window provides the following information:

- **Menus** (Server, View, Exit, Help)
- **Server Icons** (Firmware Upgrade, Virtual COM Configuration, Searching Server, Uninstall Virtual COM, Monitor Port Status)
- **IP SERIAL SERVER / Virtual COM Lists**
- **Software Status** (Ready, Updating, Searching, etc)

4.3.1 Menus

Server

- **Firmware Upgrade** - Used when downloading new firmware to the **IP SERIAL SERVER**.
- **Virtual COM Configuration** - Selects the **Virtual COM List**. Double clicking on any COM port in the **Virtual COM List** brings up a window that allows changing the virtual COM settings such as **Flow Control, Protocol, IP address, and Port Number**. Virtual COM settings must match **IP SERIAL SERVER** port settings.
- **Searching Server** - Searches for **IP SERIAL SERVER**'s on the network and brings back configuration information that will be displayed in the **Server Properties** window.
- **Uninstall Virtual COM** - Allows virtual COM ports to be uninstalled from the **IP SERIAL SERVER Manager** window.

- **Monitor Port Status** - Brings up a screen that displays the following information associated with the selected serial port:

Serial TX: Displays the number of bytes of data sent to the **serial device** since the IP connection was established.

Serial RX: Displays the number of bytes of data received from the connected **serial device** since the IP connection was established.

DTR/RTS: The **DTR/RTS Port Status** indicator displays the current logic state of the DTR and RTS hardware handshake (output) lines for the selected **IP SERIAL SERVER** port (1 = asserted, 0 = not asserted).

DCD/DSR/CTS: The **DCD/DSR/CTS Port Status** indicator displays the current logic state being received on the DCD, DSR and CTS hardware handshake (input) lines for the selected **IP SERIAL SERVER** port (1 = asserted, 0 = not asserted)

Status: Indicates whether the client software has made a connection with the **IP SERIAL SERVER**.

IP Address: Displays the IP address of the connected client when there is a client connection

- **Save Configuration File** - Allows the user to save the current configuration information to a file with a .vcom extension.
- **Load Configuration File** - Allows the user to load a configuration file.

View

Provides three viewing options for the IP SERIAL SERVER Manager screen:

- **Toolbar** – allows the toolbar (directly under the menu bar) to be viewable or hidden
- **Status Bar** – allows the Status Bar (at the bottom of the screen to be viewable or hidden
- **Split** – allows the position of the split between the Icons pane and the Virtual COM List / IP SERIAL SERVER List panes to be dragged horizontally using the mouse

Exit

- Allows you to **Exit** the **IP SERIAL SERVER Manager** program

Help

- Accesses the **About vcomui** (virtual com user interface) dialogue box, which indicates the software version number

4.3.2 Server Icons Pane

Firmware Upgrade, Virtual COM Configuration, Searching Server, Uninstall Virtual COM and Monitor Port Status can also be selected using icons located in the left window.

4.3.3 IP SERIAL SERVER / Virtual COM Lists

To make management of lists of IP SERIAL SERVER easier, lists can be sorted by clicking on any tab heading. Scrolling bars facilitate scrolling through long lists.

IP SERIAL SERVER List

- **Server Name** - Displays the name of the **IP SERIAL SERVER**. The name is listed once for each port.
- **IP Address** - Displays the IP Address for the **IP SERIAL SERVER**. All ports in a **IP SERIAL SERVER** have the same the same IP address.
- **Protocol** - Displays the currently selected TCP or UDP mode for the **IP SERIAL SERVER**.
- **Port** - Displays the port number for each **IP SERIAL SERVER** port.
- **COM Name** - Displays the name of the computer COM port mapped to each **IP SERIAL SERVER** port. If no computer port has been mapped it displays **Not mapped**.
- **Status** - The Status indicates the mapped virtual COM port condition.
 - Not Connected** is shown when a program does not have the port Open.
 - Connected** is shown when that mapped port is Open for use.

Virtual COM List

- **COM Name** - Displays the number of the COM port mapped to each **IP SERIAL SERVER** port.
- **IP Address** - Displays the IP Address for the **IP SERIAL SERVER**. All ports in a **IP SERIAL SERVER** have the same IP address.
- **Protocol** - Displays the currently selected TCP or UDP mode for the **IP SERIAL SERVER**.
- **Port** - Displays the port number for each **IP SERIAL SERVER** port.
- **Flow Control** - Indicates what type of flow control is configured for each port.
- **Status** - Indicates whether each port is currently **In Use** or **Not Used**.

4.3.4 Status Bar

Displays the current status of the software in the bottom, left corner of the screen

- Ready
- Updating
- Searching reachable servers...

4.4 Search for Servers

Upon opening the **IP SERIAL SERVER Manager** software it will automatically execute Searching Server and search for all reachable IP SERIAL SERVER DEVICES.

- Step 4:** To manually initiate a search for servers, click **Searching Servers** (under the **Servers** menu or the icon on the left side of the screen). The **Search Setup** box will appear. It provides two options for searching for servers on the network:

Specify the IP Address of the IP SERIAL SERVER or
Search all reachable servers



Figure 22 The Search Setup Window

Step 5: Enter the **IP Address** assigned to the desired **IP SERIAL SERVER** or click **Search all reachable servers**, then **OK**. **IP Address** is used to find **IP SERIAL SERVER** units that are not on the same subnet. (Routers on the network will block the standard broadcast used to find servers if **Search all reachable servers** is selected.) The user must set an IP address that conforms to the LAN addressing scheme.

The Searching window is shown until all active **IP SERIAL SERVER**'s on the LAN are listed in the **IP SERIAL SERVER List** window.

4.5 Configure Server Properties

The **Server Properties** window displays the current configuration properties for the currently selected server.

Step 6: To open the **Server Properties** window, highlight the **IP SERIAL SERVER** in the **IP SERIAL SERVER List** window, double-click to open.

The **Server Properties** window is used to configure and store the Server configuration settings. Details for setting Properties are described in the next chapter.

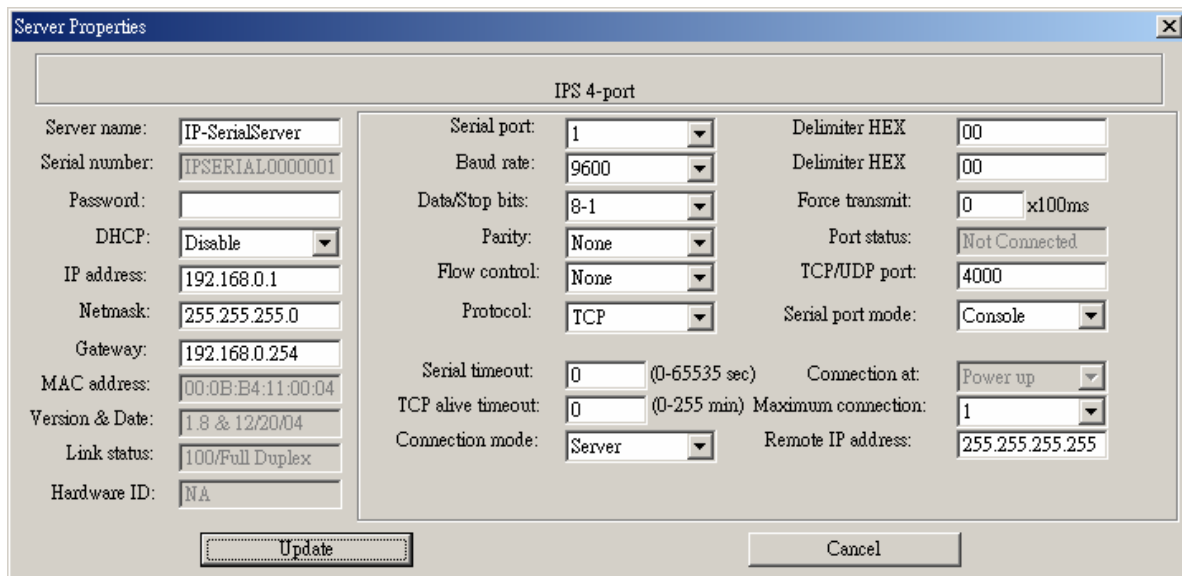

Figure 23 The Server Properties Window

Note:

IP SERIAL SERVER Manager Navigation:

- Use the mouse to select the property and parameters or
- Tab to move to the next property
- Tab+Shift to move back to previous property
- Arrows to move between properties or change values or contents of the current property
- Enter to select update or cancel

Step 7: After configuring as needed, click **Update** to store the configuration in the server. The following window will appear:

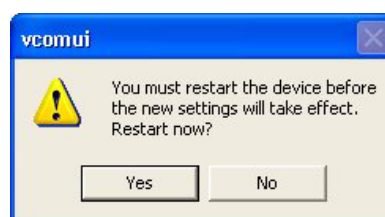

Figure 24 The Restart Dialogue Box

Step 8: Click **Yes** to restart. The following dialogue box will appear:

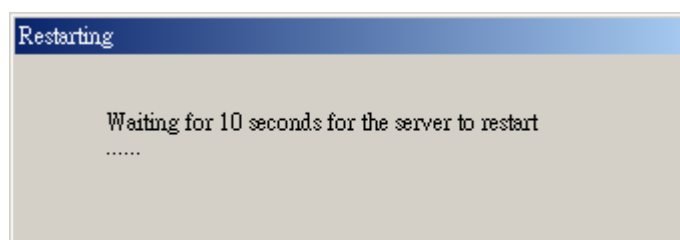

Figure 25 The Restarting Dialogue Box

After eight seconds a dialogue box will ask whether you want to search for all reachable servers again.

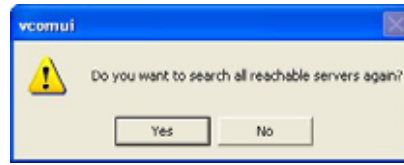

Figure 26 The Server Search Dialogue Box

While the IP SERIAL SERVER is searching for all reachable servers the following dialogue box appears:

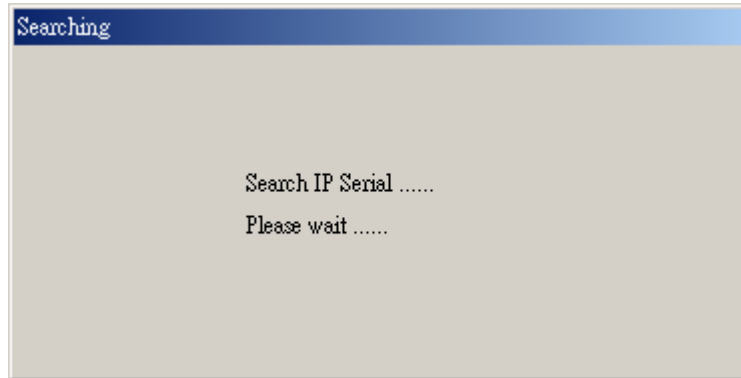

Figure 27 The Search IP SERIAL SERVER Manager Dialogue Box

After that port has been updated you may want to re-enter **Server Properties** to verify the changes have taken effect, or to view/change the configuration of other ports. Each port must be configured separately.

5. CONFIGURING THE IP SERIAL SERVER PROPERTIES

The **IP SERIAL SERVER** can be configured using any of four different user interfaces: the **IP SERIAL SERVER Manager** software, **Console Mode**, **Telnet** or the **Web Server**. The **Server Properties** described in this chapter can be changed from any of these user interfaces.

5.1 Description of the Server Properties

Server Properties	
IPS 4-port	
Server name:	IP-SerialServer
Serial number:	IPSERIAL0000001
Password:	
DHCP:	Disable
IP address:	192.168.0.1
Netmask:	255.255.255.0
Gateway:	192.168.0.254
MAC address:	00:0B:B4:11:00:04
Version & Date:	1.8 & 12/20/04
Link status:	100/Full Duplex
Hardware ID:	NA
Serial port:	1
Baud rate:	9600
Data/Stop bits:	8-1
Parity:	None
Flow control:	None
Protocol:	TCP
Serial timeout:	0 (0-65535 sec)
TCP alive timeout:	0 (0-255 min)
Connection mode:	Server
Delimiter HEX:	00
Force transmit:	0 x100ms
Port status:	Not Connected
TCP/UDP port:	4000
Serial port mode:	Console
Connection at:	Power up
Maximum connection:	1
Remote IP address:	255.255.255.255

Figure 28 IP SERIAL SERVER Manager Server Properties Window

5.1.1 Server Name

This field displays the name that has been assigned to the **IP SERIAL SERVER**. A new **Server Name** of up to 16 characters can be entered. If more than one **IP SERIAL SERVER** is connected on the LAN it is recommended that a new name be assigned to each. When the **IP SERIAL SERVER Manager** finds a **IP SERIAL SERVER** on the LAN it displays the server name and IP Address allowing the user to distinguish between **IP SERIAL SERVER**.

5.1.2 Serial Number

Each **IP SERIAL SERVER** has a unique serial number. This is fixed and cannot be changed.

5.1.3 Password

Entering a password activates a security feature on the **IP SERIAL SERVER**. Once a password is entered it will be required to access the menu and make changes.

5.1.4 DHCP

DHCP servers are a part of numerous LAN management systems. The DHCP field provides two choices:

Disable and **Enable**. Disable is the normal, or default, setting. When enabled, the **IP SERIAL SERVER** will send a DHCP request to the DHCP server, which will assign a dynamic IP address, net mask, and gateway to the **IP SERIAL SERVER**. If a DHCP server is not available on the network the **IP SERIAL SERVER** will time out after 10 seconds and the default values will remain. When DHCP is enabled, the IP Address, Netmask and Gateway fields become inaccessible and cannot be changed by the user.

Note:

A dynamic address assigned by the DHCP server may change if the server loses the Ethernet connection or power is removed. The host (client) communication software requests a connection to the specific IP address of the IP SERIAL SERVER. If the DHCP reassigns a different IP address the software will not be able to communicate with the hardware. Therefore, using a static IP address is recommended.

5.1.5 IP Address

Software or hardware attempting to access the **IP SERIAL SERVER** via the network must know the **IP Address** of the server. A static IP address is retained and remains the same each time the server is powered up or starts/restarts. The default IP address of the **IP SERIAL SERVER** is printed on a label on its bottom cover. Entering an appropriate address in the IP Address field and updating the server will change the server's IP address. The network administrator can assign/establish the static address or group of addresses to be used.

The IP Address of the **IP SERIAL SERVER** can be confirmed using the DOS Ping command.

Note:

To use Ping to check for communications:

- Access a DOS window (in XP click **Start**, then **Run**)
- At run prompt enter: **CMD**
- In the DOS window enter: **Ping xxx.xxx.xxx.xxx** (IP address for the server to be confirmed)
- The command will return the Ping results indicating 4 replies

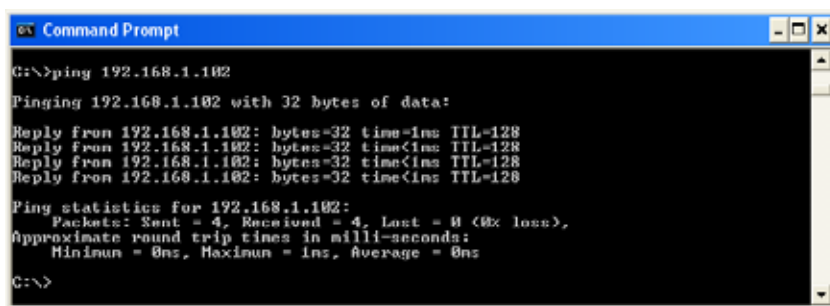

Figure 29 Pinging using the DOS command window

5.1.6 Netmask

The default LAN netmask is configured for a Class C address. The user may change this. Default is 255.255.255.0

5.1.7 Gateway

The Gateway IP address allows users to access the **IP SERIAL SERVER** from outside the LAN.

5.1.8 MAC Address

The MAC address is fixed and cannot be changed. It is assigned in the factory. Every Ethernet device manufactured has its own unique MAC address.

5.1.9 Version & Date

The currently loaded version of the firmware, and when it was released, is shown here.

5.1.10 Link Status

Link status automatically displays the type of Ethernet connection. It will either display 10BaseT or 100BaseTX in full duplex or half duplex. This will depend on the LAN, switches, hubs used in the LAN topology.

5.1.11 Server Serial Port

This field indicates the number of the port for which **IP SERIAL SERVER** properties are currently being displayed. Changing the number in this field will cause all the other fields to display the properties for the specified port. Note, however, that before changing ports, any changes to properties must be **Updated** (Saved) or the **IP SERIAL SERVER** will not retain them.

5.1.12 Baud Rate

The serial port baud rate on the **IP SERIAL SERVER** must match the serial baud rate of the connected device unless using Virtual COM Mode. In Virtual COM Mode the software program will establish serial settings.

5.1.13 Data/Parity/Stop

Set this to match the data format used by the serial device connected when Virtual COM Mode is not being used.

5.1.14 Flow Control

The Flow Control setting must match the requirements of the serial device connected.

Note:

Select None when setting the port as RS-485 or 4-wire RS-422.

5.1.15 TCP/UDP Protocol

Select **TCP** (Transmission Control Protocol) or **UDP** (User Datagram Protocol) protocol. If the application does not require a UDP connection, select TCP. TCP guarantees reliable communication with error checking whereas UDP provides faster transmission.

UDP Mode

When UDP mode is chosen the **Serial timeout**, **TCP alive timeout**, **Connection mode**, **Connection at**, **Max connection** and **Remote IP address** fields are replaced with the following four fields: **Destination IP address range**, **Port number** and **Source IP address range**. In this mode the server can be configured to broadcast data to and receive data from multiple IP addresses. Four IP address range fields are provided.

The screenshot shows the 'Server Properties' dialog box with the 'UDP' protocol selected. The 'IPS 4-port' section is active, showing four rows of configuration for different ports. The 'Port' field is set to 4000 for all rows, and the 'Source IP address range' is set to 0.0.0.0 for all rows. The 'Destination IP address range' is also set to 0.0.0.0 for all rows. The 'Serial port mode' is set to 'Console'.

Destination IP address range:	Port:	Source IP address range:
0.0.0.0 to 0.0.0.0	4000	0.0.0.0 to 0.0.0.0
0.0.0.0 to 0.0.0.0	4000	0.0.0.0 to 0.0.0.0
0.0.0.0 to 0.0.0.0	4000	0.0.0.0 to 0.0.0.0
0.0.0.0 to 0.0.0.0	4000	0.0.0.0 to 0.0.0.0

Figure 30 The Server UDP Configuration Screen

5.1.16 Serial Timeout

Default for the **Timeout** property is 0, or no timeout. Setting **Timeout** to any value between 1 and 65535 seconds activates it. If **Timeout** is set to 5 seconds and the **IP SERIAL SERVER** is configured as a **Server**, the **Client** makes a connection and communications starts. If communications are idle for 5 seconds the **IP SERIAL SERVER** will reset and make itself available for another client connection.

5.1.17 TCP Alive Timeout

The **IP SERIAL SERVER** monitors TCP activity. If TCP activity stops for the length of time specified in this field the connection will be closed. This field can be set to any value between 0 and 255 minutes. If zero, or no value, is entered into this field the server will not disconnect.

5.1.18 Connection Mode

The Connection Mode field has three options: **Server**, **Client** and **Client (no heartbeat)**. When **Client** or **Client (no heartbeat)** is selected the **Connection at** field automatically becomes active (allowing the user to select **Power up** or **Data Arrival**).

- When using the **Virtual COM Port** feature, select **Server**.
- When using a **TCP** or **UDP Socket** program, select **Server**.

- When using **Paired Mode** communication between two IP SERIAL SERVER's set up one as a **Client** and the other as a **Server**.
- When connecting to a server that does not support **Heartbeat**, select **Client (no Heartbeat)**.

5.1.19 Delimiter HEX 1 and Delimiter HEX 2

These fields allow the user to enter two ASCII characters (in hex format) that delimit the beginning and end of a message. When a message with both these delimiters is received at the serial port, the data contained in the serial buffer is placed in an Ethernet packet and sent out the Ethernet port. If only Delimiter 1 is set (Delimiter 2 is zero or blank), upon receiving Delimiter 1 the IP SERIAL SERVER will put all the data in the serial buffer in an Ethernet packet and send it out the Ethernet port. If serial data greater than 1 kilobyte is received it will automatically be placed in an Ethernet packet and sent out the Ethernet port .

5.1.20 Force Transmit

This field allows the user to set a maximum time limit between transmissions of data. The value set in this field multiplied by 100 ms determines the Force Transmit time. When the elapsed time reaches the time configured in this field, the TCP/IP protocol will pack the data currently in the serial buffer into a packet and send it out the Ethernet port.

5.1.21 Port Status

This field indicates whether a serial port is connected via the **IP SERIAL SERVER** to a virtual COM port of a device on the network.

5.1.22 TCP/UDP Port

This sets the port number for connection. The default port number for the **IP SERIAL SERVER** is **4000** for serial port 1.

In all modes of operation, **Direct IP** or **Virtual COM**, the port number set in the **Server Properties** menu must match the **Virtual COM** or socket software port settings.

Note:

Example: The Virtual COM default setting is TCP/UDP Port 4000. If the port # property is changed to 4001, the virtual COM port will have to be changed to 4001. The hardware settings can be changed from the IP SERIAL SERVER Manager or Console Configuration Menu. The Virtual COM port setting also can be changed within the Device Manager of the computer on which it is installed.

5.1.23 Serial Port Mode

Serial Port Mode allows configuration of the IP SERIAL SERVER for the following modes of operation:

- **Console** – When this mode is selected and the server is updated, a PC running a communications program such as HyperTerminal can communicate with the **IP SERIAL**

SERVER via the **Console Mode** serial port, displaying the **Server Properties** screen and allowing configuration of the server and its ports.

- **Upgrade** – When this mode is selected and the server is updated, firmware can be uploaded into the **IP SERIAL SERVER** via the **Console Mode** serial port or a virtual COM port mapped to the number of the **Console Mode** serial port.
- **Default** – When this mode is selected and the server is updated, it will revert the server to its default configuration.
- **RS-232** – When this mode is selected and the server updated, the selected serial port will become an RS-232 serial port on the server.
- **RS-422** – When this mode is selected and the server updated, the selected serial port will become an RS-422 serial port on the server.
- **RS-485** – When this mode is selected and the server updated, the selected serial port will become an RS-485 serial port on the server.

5.1.24 Connection At

When the **Connection Mode** field is set to **Client** or **Client (no heartbeat)**, this field becomes active, allowing the **IP SERIAL SERVER** (acting as a client) to connect to the server either on **Power up** or on **Data Arrival** (first character arriving).

5.1.25 Max Connection

This field allows the user to configure the **IP SERIAL SERVER** to have up to eight TCP connections.

5.1.26 Remote IP Address

This is a security feature activated by entering the IP address of the desired client. The **IP SERIAL SERVER** will only communicate with the listed IP address and all other requests for connection will be filtered out. The **IP SERIAL SERVER** must be set up as a **TCP** or **UDP Server** to use this feature. The default setting is **255.255.255.255**.

If **Paired Mode** is not being used, do not change this setting until the application has been tested and is communicating properly. Then activate the address filtering feature.

5.1.27 Update/Save

Server properties must be updated separately for each serial port. Updating varies slightly depending on which of the four configuration user interfaces are used.

Updating the Server Properties in IP SERIAL SERVER Manager

From the **Server Properties** screen, click the **Update** button to store the configuration settings for the currently selected port. The vcomui dialogue box will appear indicating you must restart the device before the new settings will take effect. Click **Yes**.



Figure 31 The Restart Dialogue Box

After that port has been updated you may want to re-enter **Server Properties** to verify the changes have taken effect, or to view/change the configuration of other ports. Each port must be configured separately.

Saving Configuration Data in Console Mode or Telnet

Saving (updating) server properties is done from the **Configuration** screen. Access the **Configuration** screen by tabbing through the list of screens on the left side of the window and highlighting **Configuration**.

There are four options shown on the right side of the **Configuration** screen: **Save**, **Default**, **Running** and **Reset**. Use **Tab**, **Backspace**, or **arrow** keys to move the cursor to the option position, and then press **Enter**.

- **Save** stores the configuration data to the **IP SERIAL SERVER** flash memory and resets it.
- **Default** restores the configuration data to factory default settings.
- **Running** restores the configuration data to the last values stored in the flash memory.
- **Reset** re-boots the **IP SERIAL SERVER**, making it available for a client connection.

Web Server Interface

- The **Web Server** interface provides the same updating options as **Console Mode** and **Telnet**. These are located at the bottom of all three **Web Server** pages. If a field is changed, you must click **Save** before leaving that page or the changes will be ignored.

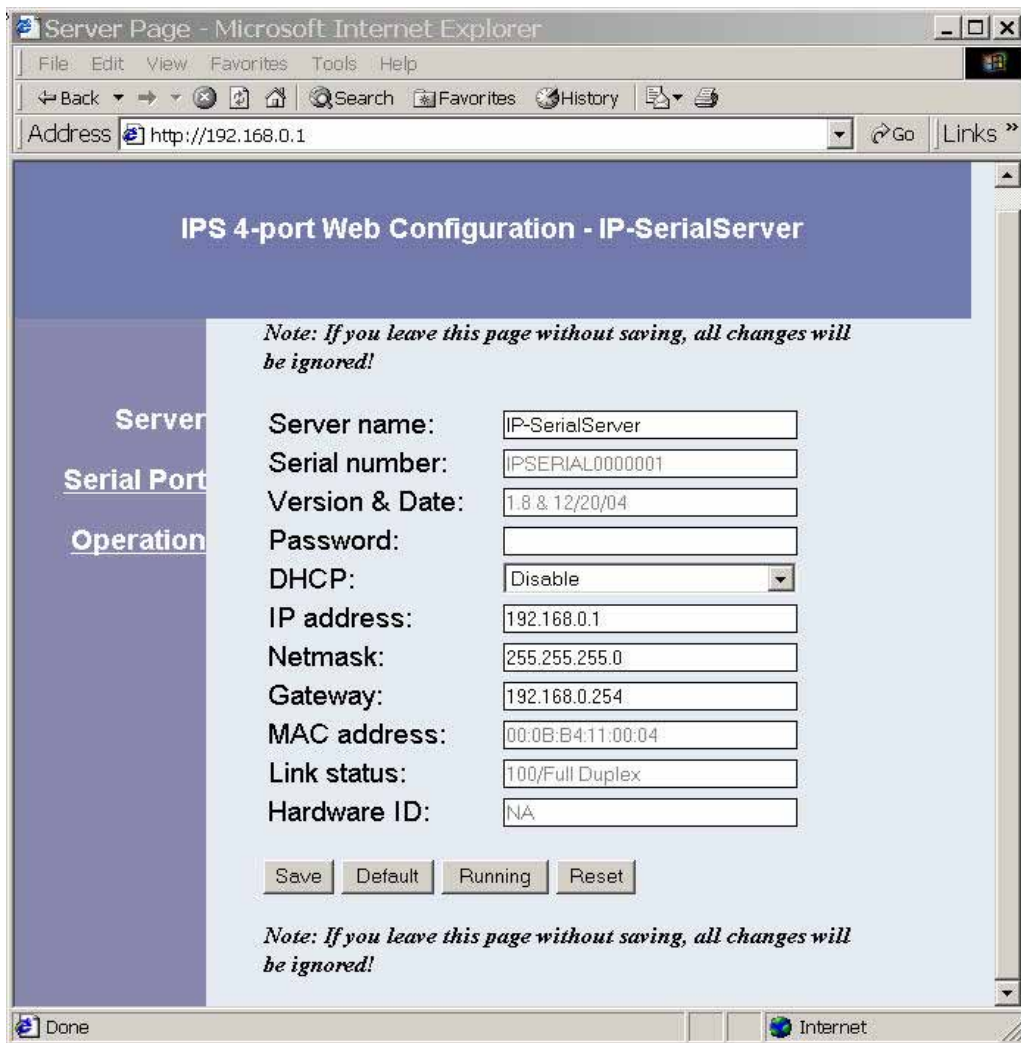

Figure 32 The Web Server Page

Note:

If you leave any Web Server page without saving, any changes you have made will be ignored.

6. INSTALLING VIRTUAL COM PORTS

The **Virtual COM Port** feature allows Windows platform software, using standard API calls, to be used in an Ethernet application.

The **Install Virtual COM Port** software adds a **IP SERIAL SERVER (COM#)** port to the computer. This shows up in the **Device Manager**. The COM number can be selected from a list of available numbers. For example, in a computer already having a COM1 and COM2, COM3 to COM 254 are available for the **IP SERIAL SERVER**. It is recommended that COM Port 5 or higher be selected. The virtual COM port looks like a standard COM port to most Windows based applications which allows the software to open a connection with the serial port located anywhere on the LAN/WAN. When using the virtual COM port the **IP SERIAL SERVER** is configured as a TCP or UDP Server.

6.1 Virtual COM Port Installation

Step 1: From the **Windows Desktop**, click:

Start → Programs → Remote Management System → RMS → IP Serial server → Install Virtual COM

The **Search Setup** window will appear.

Step 2: Select the **Search all reachable servers** check box, then click **OK**.



Figure 33 The Search Setup Window

The program searches the LAN for all available **IP SERIAL SERVER**. When complete, the **Found Server** window appears and displays a list of the servers that were found.

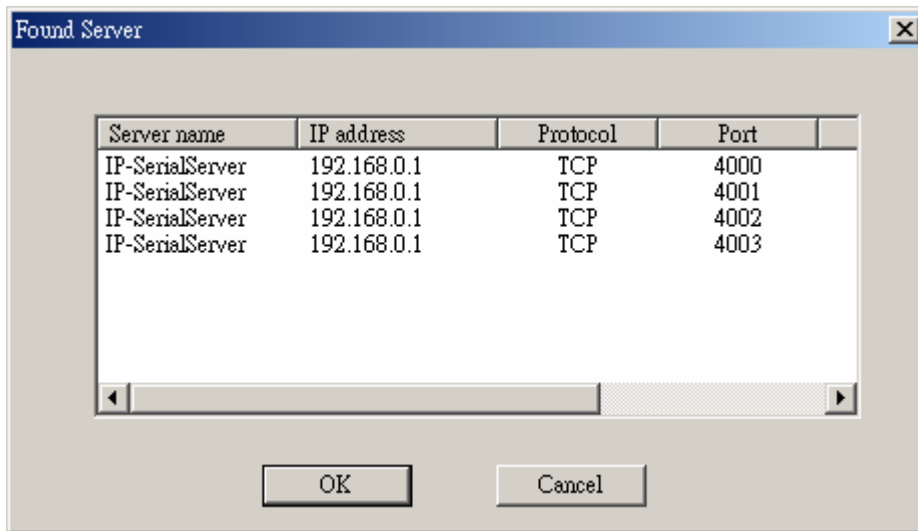

Figure 34 The Found Server Window

Step 3: Select the **IP SERIAL SERVER** at the IP Address to be mapped to a virtual COM port, then click **OK**.

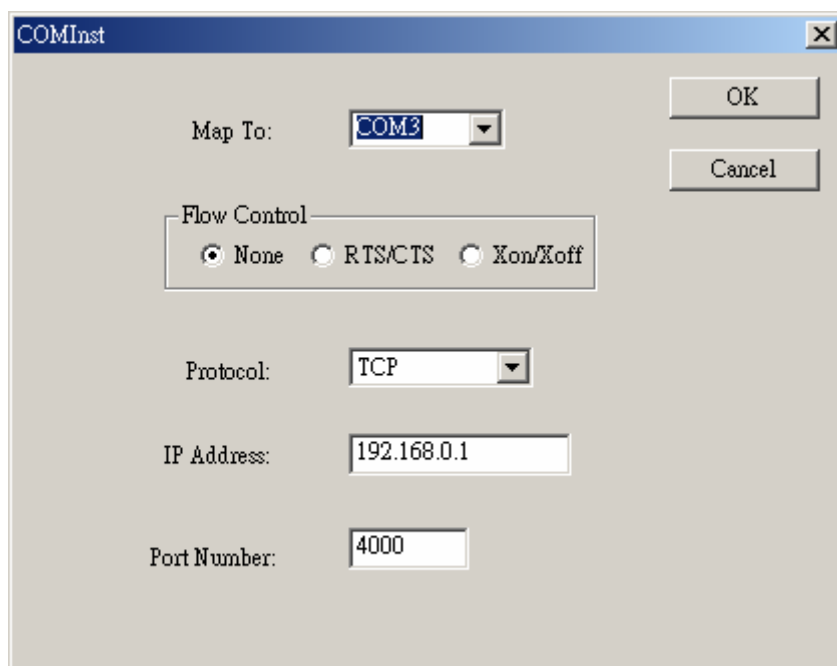

Figure 35 The COMInst Window

The Protocol TCP/UDP, IP Address, and Port Number will mirror the settings of the selected IP SERIAL SERVER.

The default **Flow Control** setting is **None**. RTS/CTS can be selected if used by the application program and serial hardware. The **IP SERIAL SERVER** must be set to match.

6.2 Matching the IP SERIAL SERVER and Virtual COM Port Settings

The settings of the virtual COM ports in the **Device Manager** and the **IP SERIAL SERVER Configuration Menu** must match. If the settings do not match, the virtual COM ports will not work. If these settings are changed in the **Device Manager**, it will only affect the operation of the virtual COM port. It will not change the settings stored in the **IP SERIAL SERVER**. Use the **IP SERIAL SERVER Manager** to change the **IP SERIAL SERVER** settings.

Step 1: Use Device Manager to **View New Ports**. Confirm the virtual COM ports in the Device Manager.

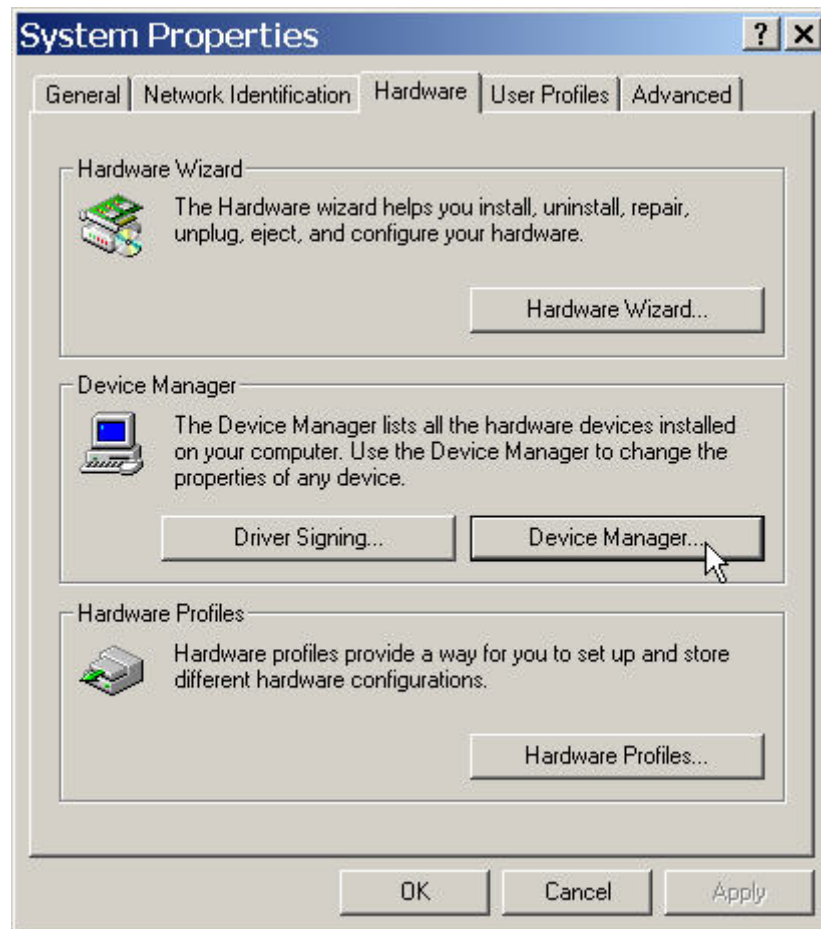

Figure 36 The Control Panel Window

Step 2: Double-click **Ports** to view the list of COM port numbers.

The installed Virtual COM port will be displayed as **IP SERIAL SERVER Manager (COM #)**.

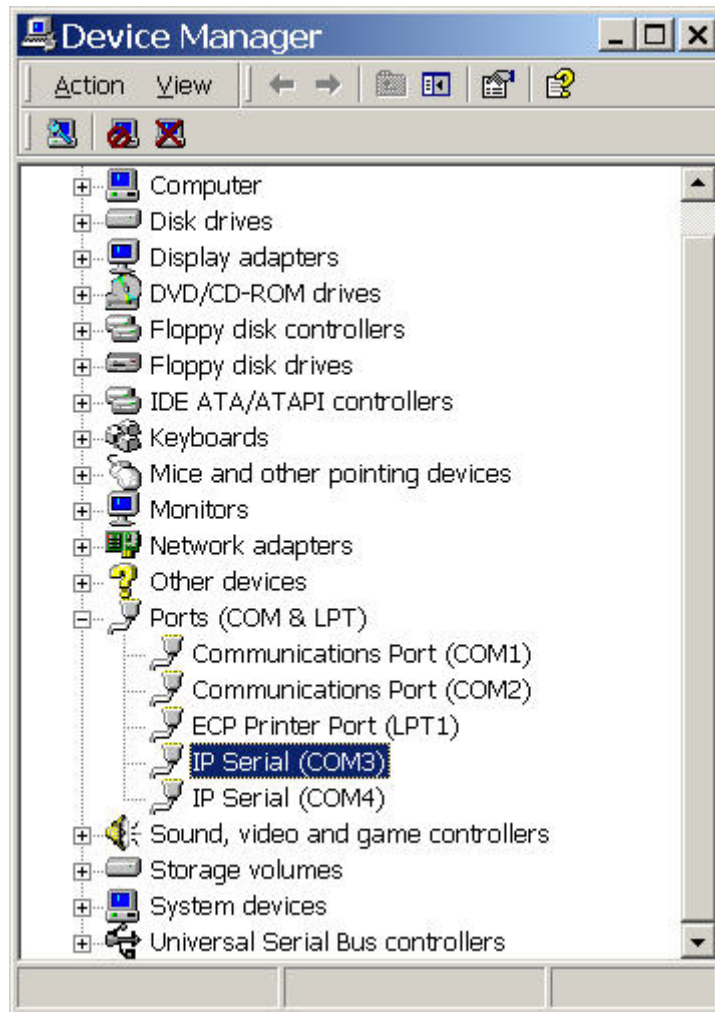

Figure 37 The Device Manager Window

Step 3: In the Device Manager select the **IP SERIAL SERVER Manager COM #**. Double-click it to bring up the **Properties** window.

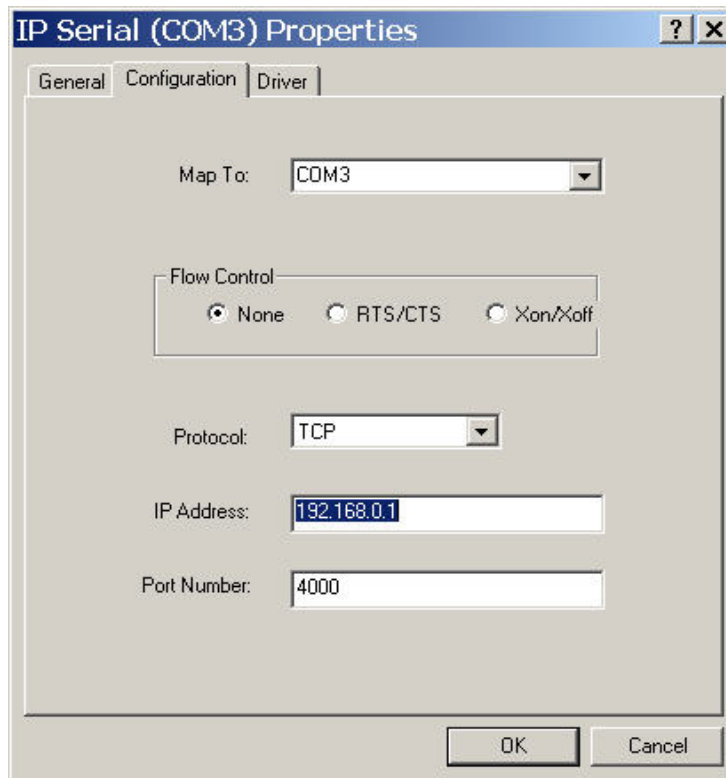

Figure 38 Virtual Com Port Properties Window

Step 4: Click the **Configuration** or **Port Settings** tab. This screen allows the settings to be changed if necessary. Click **Cancel** to keep the existing settings.

Step 5: Click **OK** to change the settings. Use **Refresh** in the Device Manager if Windows does not auto refresh.

7. REMOVING VIRTUAL COM PORTS

The **IP SERIAL SERVER Manager** software **Uninstall Virtual COM Port** feature will remove a mapped COM port in the Device Manager of Windows 2000 and XP operating systems. It may also be removed in the Device Manager of Windows 98, ME, NT, 2000, and XP. Windows 98 users also will find a **Remove Virtual COM** feature in the Programs file.

7.1 Removing the Virtual COM port with IP SERIAL SERVER Manager

Step 1: From the Windows Desktop, click:

Start → Programs → Remote Management System → RMS → IP SERIAL SERVER → IP Serial Manager → IP Serial Manager

Step 2: In the **IP SERIAL SERVER Manager** window click the **Virtual COM List** tab. Highlight the mapped COM port number to be removed.

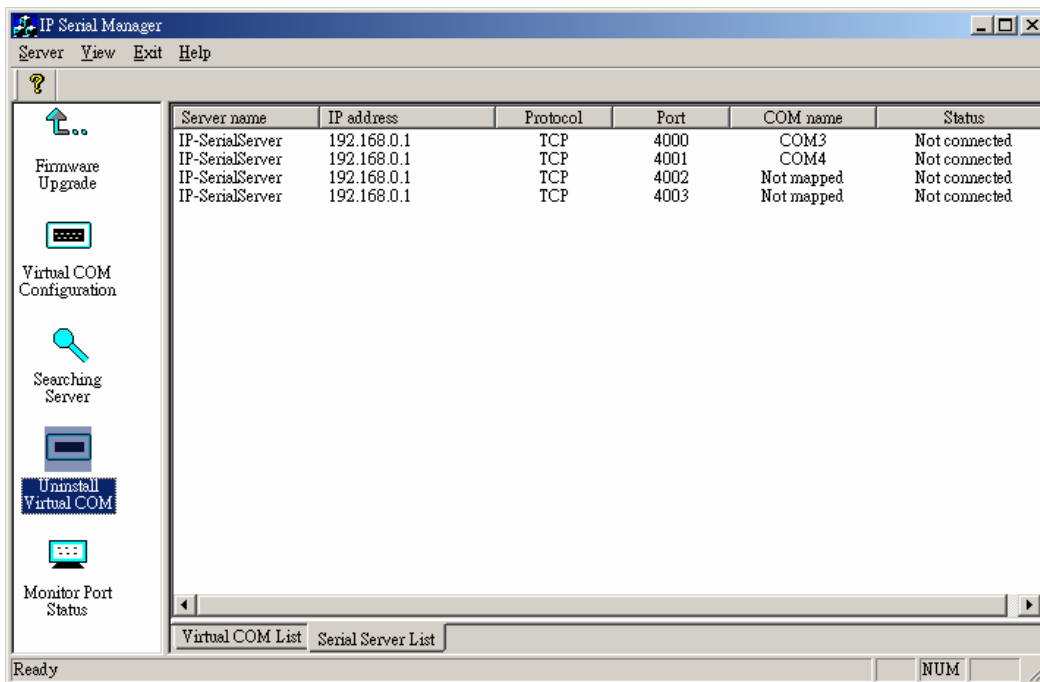

Figure 39 The IP SERIAL SERVER Manager Window

Step 3: Click the **Uninstall Virtual COM** icon. The Manager will ask for conformation. Click **OK** to complete the uninstall procedure.

7.2 Removing the Virtual COM Port using Device Manager

Step 1: From the Windows **Desktop** click:

Start → Settings → Control Panel.

Step 2: Click the **System** icon when the manager window opens.

Step 3: Click **Device Manager** in the **Systems Properties** window. In the Device Manager dialogue click the **+** next to **Ports (COM & LPT)** to expand.

Step 4: Highlight **IP SERIAL (COM #)** to be removed and click the **Action** tab at the top of window, then click **Uninstall**. A confirm **Device Removal** window will appear.

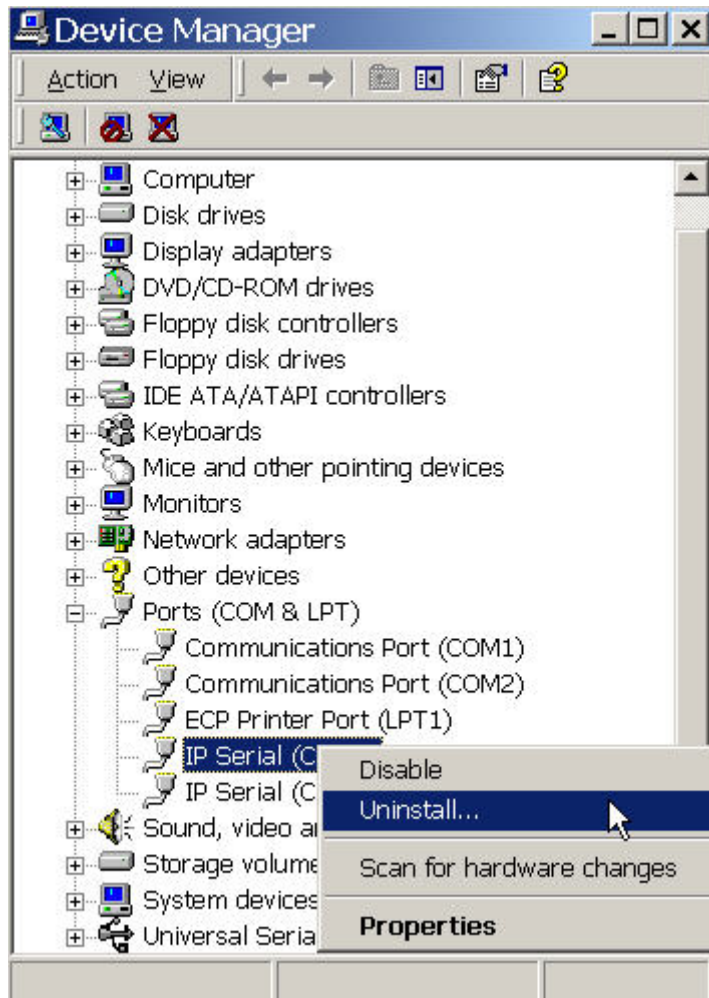

Figure 40 Confirm Device Removal

Step 5: click **OK** to proceed.

The **IP SERIAL SERVER Manager COM #** will be removed and the Device Manager window will refresh and display the remaining COM ports

8. UPGRADING THE IP SERIAL SERVER FIRMWARE

New **IP SERIAL SERVER** firmware updates may become available through the website for installation into the server. The firmware can be uploaded using either a virtual COM port connection or hardware COM port connection.

8.1 Downloading the Firmware

Make a folder to receive the firmware file. Download the compressed software file from the website. Unzip or expand the file into the (.hex) format so it will be ready to upload to the **IP SERIAL SERVER**.

8.2 Upgrading Via IP SERIAL SERVER Manager

The **IP SERIAL SERVER Manager** software can upload new firmware to the server using a direct PC connection via the **IP SERIAL SERVER** serial port or using a virtual COM port.

Note:

If connecting directly to a computer serial port, use a null modem cable between the Computer RS-232 port and the IP SERIAL SERVER serial port or Port 1.

8.2.1 Preparing the Software

Step 1: In the **IP SERIAL SERVER Manager IP SERIAL SERVER List** window, double click the server to be upgraded. The **Server Properties** window will appear.

Step 2: If using a direct connection to upload the firmware to the **IP SERIAL SERVER**, set the baud rate to **115200** for the fastest possible upload.

Step 3: Set the **Serial Port** field to upgrade and click the **Update** button. (Ensure that the DIP switches on the **IP SERIAL SERVER** are all in the OFF position.)

Step 4: Click **Yes** on the **vcomui** dialogue to restart the **IP SERIAL SERVER**.

8.2.2 Upgrading the Firmware

Step 5: Double-click the **Firmware Upgrade** icon (or click the **Server** menu and **Firmware Upgrade**)

Step 6: In the **Upgrade** window, click **Browse**. The **Open** dialogue box will appear. Locate the folder on your PC that contains the firmware .hex file. **Select** the file and click **Open**. The **Open** dialogue box will disappear.

Step 7: In the **Upgrade** window select the serial port to be used in transferring the firmware.

If connected directly from the PC to a **IP SERIAL SERVER** port it will typically be COM1 or COM2

If using a virtual COM port to upgrade via the network, identify the virtual COM number and address mapped to Port 1 on the **IP SERIAL SERVER**.

Step 8: Click **Upgrade**

Step 9: In the **Port Settings** window set the **Bits per second**, **Data bits**, **Parity** and **Stop bits** to the same values as set up in the **Server Properties** window. Click **OK**.

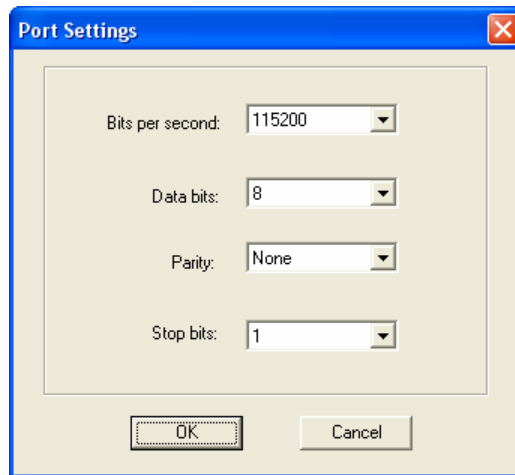

The Port Settings Window

Step 10: Upgrade progress will be shown until the **Upgrade finished!** message is shown. Click **OK**.

9. USING CONSOLE MODE

Before the **IP SERIAL SERVER** is installed on a LAN the **Console Mode** can be used to change the settings from the defaults. The **IP SERIAL SERVER** is shipped in the **RS-232 Mode**. Connect a crossover (null modem) cable between the COM port on the computer and the appropriate serial port on the **IP SERIAL SERVER**.

9.1 Console Mode Setup

Step 1: Apply power to the **IP SERIAL SERVER**. The power and ready LED will light.

Step 2: Using a VT100 Terminal emulation program (typically **HyperTerminal** in Windows) open the computer COM port connected to the **IP SERIAL SERVER** (via an RS-232 crossover / null modem cable).

Step 3: In the HyperTerminal **Port Settings** window set:

Baud rate: 9600

Data bits: 8

Parity: None

Stop bits: 1

Flow control: None

Click **OK**

Step 4: Ensure all the DIP switches are in the ON position.

Step 5: To view the **Configuration Menu**, press the **space bar**. The menu will appear within a few seconds.

9.1.1 Navigating the Configuration Menus

There are six **Console Mode** screens: **Server**, **Network**, **Serial Mode**, **Operation**, **Monitor** and **Configuration**. **Tab**, **Back Space** and **arrow** keys can be used to highlight the desired function on the screen list. Pressing **Enter** moves the cursor to the first field with the current screen. The configuration fields can be changed by pressing **Enter** and selecting from the list that appears. The **Escape** key moves the cursor back to the screen list. Pressing the **Space Bar** refreshes the page.

Step 5: Once all the changes have been made move to the **Configuration** screen, select **Save** and press **Enter**.

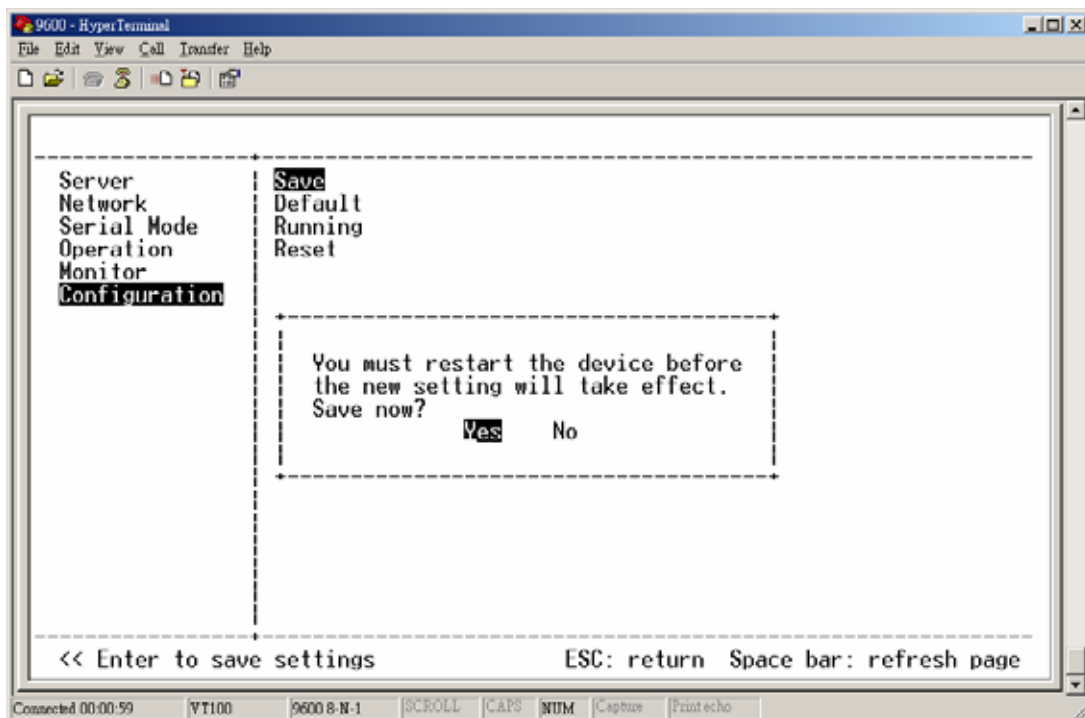

Figure 41 Saving and Restarting the Configuration

The restart message will appear.

Step 6: Select **Yes** to save changes. This is necessary to write the settings to the server.

9.1.2 Using a Password

If a password is used it must be entered before the Configuration screen can be seen. If the server is accessed with a password but no changes are made, **Reset** to end before disconnecting.

10. USING THE WEB SERVER

The Web Server can be used to configure the **IP SERIAL SERVER** from any web browser software (such as Internet Explorer). Server properties can be set up using three browser pages.

10.1 Setting Server Properties

In Internet Explorer type the IP Address of the **IP SERIAL SERVER** into the address field near the top of the window and press the **Enter key**. The following window will appear:

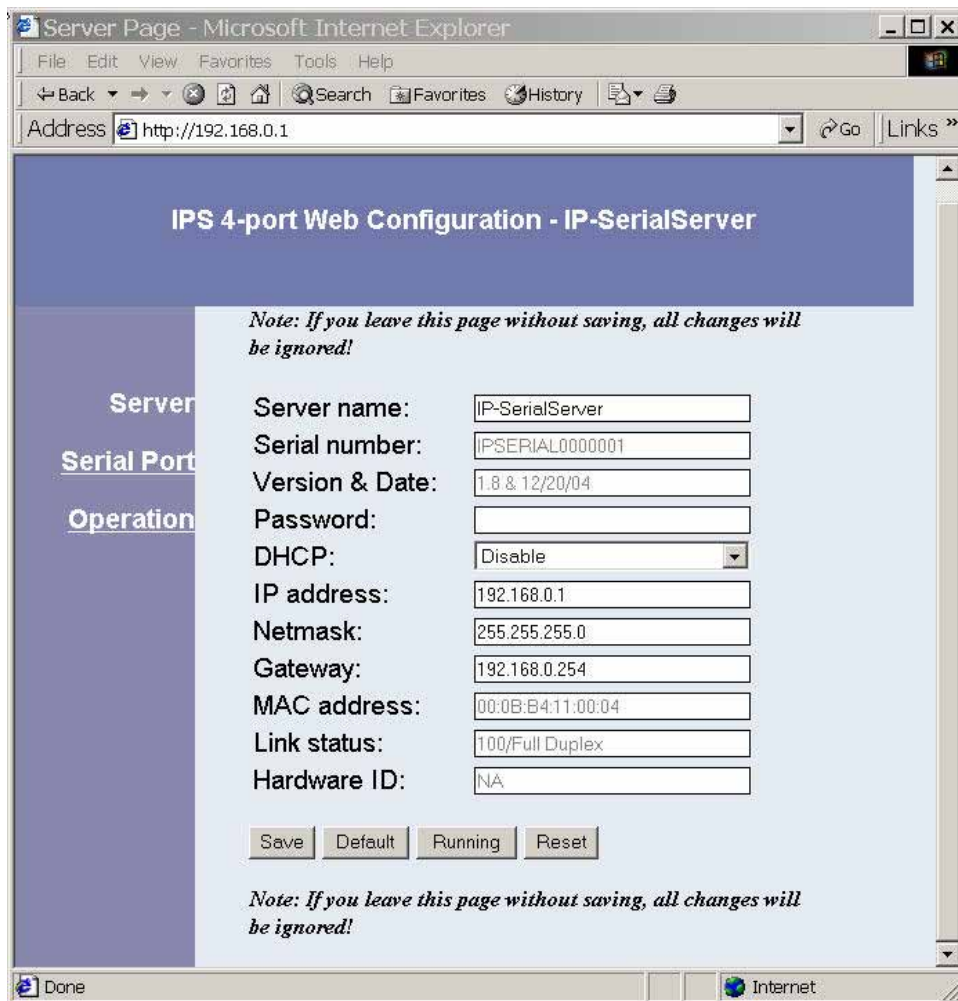

Figure 42 The Web Server Page

Navigate and change properties as required using the mouse and keyboard.

To change serial port properties, click **Serial Port** on the left side of the browser window. The following page will appear:

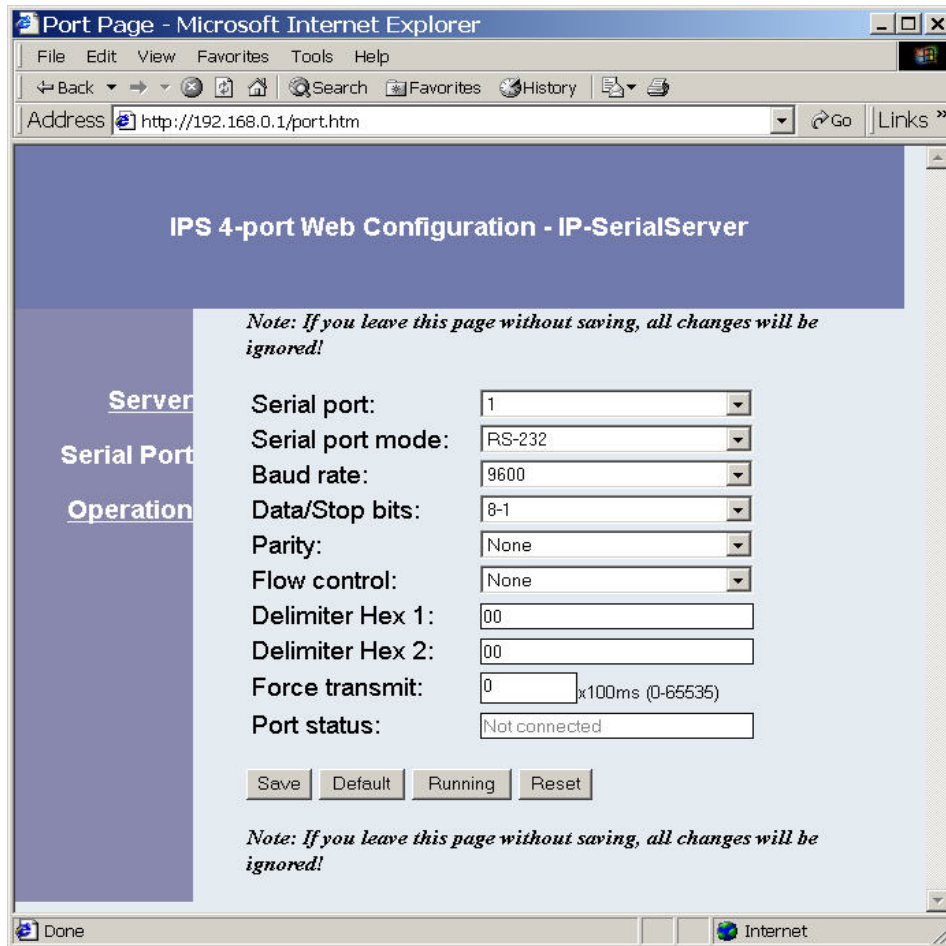

Figure 43 The Web Server Serial Port Properties Page

To change other operational properties, click **Operation** on the left side of the browser window. The following page will appear:

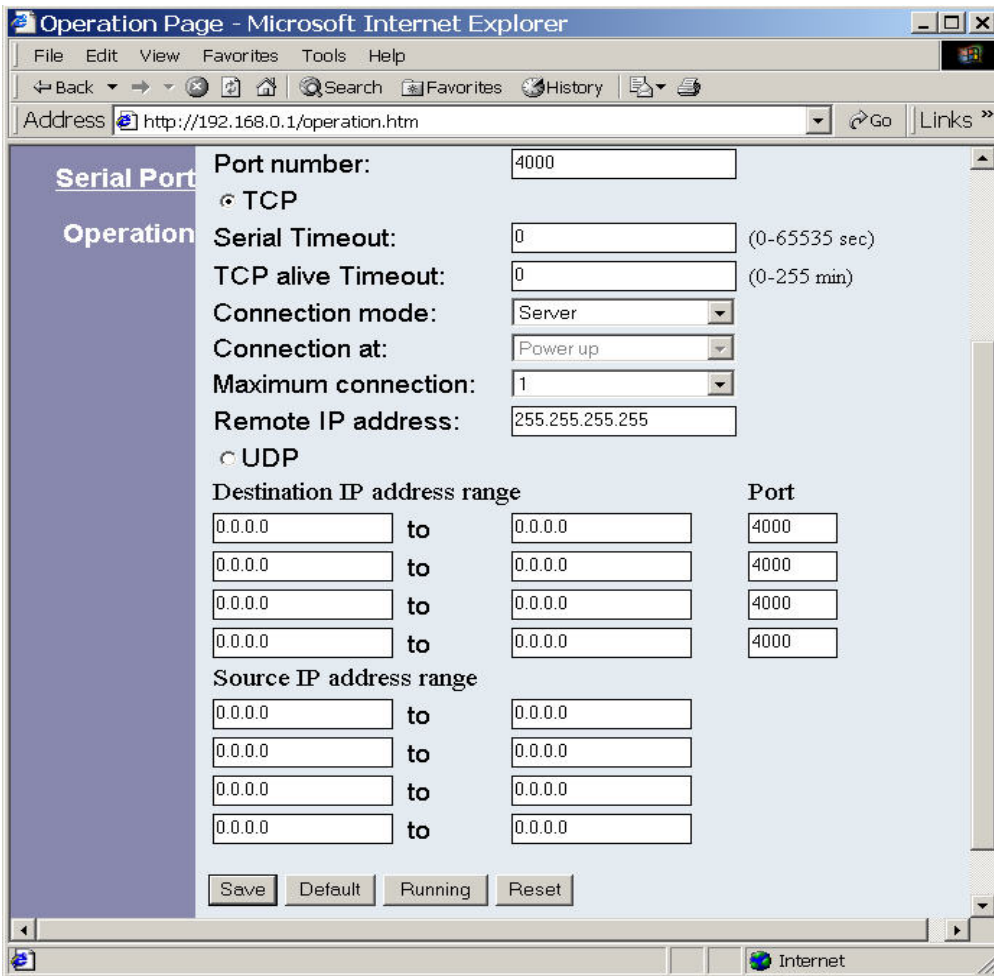

Figure 44 The Web Server Operation Page

Click **Save** to store changes to the **IP SERIAL SERVER**. Settings for each Port must be saved separately.

Note:

If new property settings are not saved before leaving this page they will not take effect.

Return to the main Server page by clicking on **Server** on the left side of the browser window.

11. USING TELNET

Telnet can be used to configure the **IP SERIAL SERVER** from any PC on the LAN. The **Telnet** window displays the same configuration information shown in **Console Mode** and allows server properties to be configured.

11.1 Configuration Using Telnet

Step 1: Ensure the PC and **IP SERIAL SERVER** are connected to the LAN.

Step 2: Apply power to the **IP SERIAL SERVER**. The power and ready LED will light.

Step 3: If the DIP switches on the **IP SERIAL SERVER** all are in the ON position (Console mode), switch them to the OFF position. The **IP SERIAL SERVER** will revert to the operational mode it was in before the switches were all set to ON.

Step 4: From the **Desktop**, click **Start**, then **Run**. The Run dialogue box will open.

Step 5: Type in **Telnet** and the IP address of the **IP SERIAL SERVER** to be configured, then click **OK**.

Note:

The IP SERIAL SERVER must be in RS-232, RS-422 or RS-485 mode before you can Telnet to it and access the configuration screens. If it was last configured in Console mode you may not be able to access it using Telnet. In this case use IP SERIAL SERVER Manager, Console Mode or Web Server for configuration.

Step 6. The **Telnet** window will open (unless the server is still in Console mode) and the **Server** screen will appear.

11.1.1 Navigating the Configuration Menu

There are six **Telnet** screens: **Server**, **Network**, **Serial Mode**, **Operation**, **Monitor** and **Configuration**. **Tab**, **Back Space** and **arrow** keys can be used to highlight the desired function on the screen list. Pressing **Enter** moves the cursor to the first field with the current screen. The configuration fields can be changed by pressing **Enter** and selecting from the list that appears. The **Escape** key moves the cursor back to the screen list. Pressing the **Space Bar** refreshes the page.

Figure 45 Telnet Configuration Screens

Step 7: Once all the changes have been made move to the **Save** field and select **Enter**. The restart message will appear.

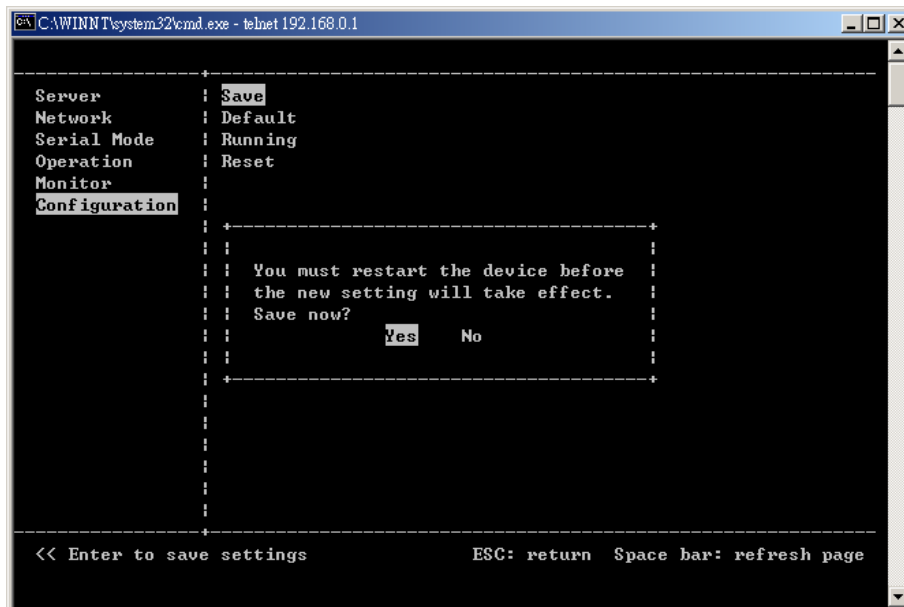

Figure 46 Saving and Restarting the Configuration

Step 8: Select **Yes** to save changes. This is necessary to write the settings to the server. The Telnet window will disappear.

Step 9: To view the changes re-enter **Telnet** and re-establish communications. The configuration menu will appear and display the current settings.

12. TECHNICAL DATA

12.1 IP Serial Server Feature List

	IPS 1-port IPS 2-port	IPS 4-port IPSL 4-port
General		
LED: Power, Link, Ready, Tx/Rx		
Dip Switch: select Consloe or Normal		-
Push button for Reset		
LCM display and keypad	-	IPL-E104S
OS supported: Windows XP/2000/NT/98/ME		
Serial Interface		
Serial Port Mode		
RS-232		
RS-422F		
RS-485H		
RS-485F	-	-
Current Loop	-	-
Serial Connector		
DB-9 male		
Terminal Block	-	-
RJ-45	-	-
Baudrate (110 to 230.4Kbps, 5787pbs)		
Data bits (5, 6, 7, 8)		
Stop bits (1, 1.5, 2)		
Parity (None, Even, Odd, Space, Mark)		
Flow Control (None, RTS/CTS, Xon/Xoff)		
Data Packing Delimiter 1 and 2		
Forced Transmit		
LAN Interface		
RJ-45 connector		
IEEE802.3 10/100BaseT		
Auto-detecting		
Full/Half-duplex selectable		
Communication Modes		
TCP Server		

TCP Client (w/ Heartbeat)		
TCP Client (no Hearbeat)		
Virtual COM mode		
Winsock mode		
UDP		
Paired Mode		
WinSock Lib. API		
Protocols		
TCP, UDP, IP, ARP, ICMP, HTTP, Telnet, DHCP,		
UDP Multicast		
Client requests connection at Power up or Data arrival		
TCP Inactivity Time (TCP alive time)		
Serial Inactivity Time		
Multiple TCP Client Connections	8 per port	8 per port
Port Monitoring		
Management		
Console		
Telnet		
Web pages		
Remote Manager		
Firmware upgrade		
Web pages upgrade		
Import/Export Configurations file		
Export Configurations file to multiple units		
Security		
Password Access		
IP Address Filtering		
Power & Environment		
DC Input	12VDC, 300mA, 500mA,	12VDC, 500mA
Operating Temperature	-10 to 80 °C	-10 to 80 °C
Storage Temperature	-20 to 85 °C	-20 to 85 °C
Humidity 0 – 90% non-condensing		
Certifications		
CE, FCC		
Mechanic		
Case -- IP30 Metal/aluminum		
Metal Housing		
DIN rail mount		

Panel mount		
Diemnsions	8.5 x 11.5 x 2.3 cm 11.4 x 18.5 x 2.9 cm 10.7 x 18.5 x 2.93 cm	11.4 x 18.5 x 2.9 cm

12.2 Default Settings

IP Serial Server Default Settings

Server Name	IP-SerialServer
Serial Number:	xxxxxxxx (printed on bottom of unit)
Password:	Blank
DHCP:	Disable
IP Address:	192.168.0.1
Net Mask:	255.255.255.0
Gateway:	192.168.0.254
MAC Address:	Fixed – see bottom label
Version&Date:	current firmware version number & date
Serial port:	1
Baud Rate:	9600
Data//Stop:	8-1
Parity:	None
Flow Control:	None
TCP/UDP Protocol:	TCP
Serial timeout:	0 seconds
TCP alive timeout:	0 minutes
Connection Mode:	Server
Delimiter HEX 1:	00
Delimiter HEX 2:	00
Force transmit:	0 ms
TCP/UDP port:	Port 1: 4000 Port 2: 4001 Port 3: 4002 Port 4: 4003
Serial port mode:	IPS 1-port & IPS 2-port: RS-232 for all ports IPS 4-port: console for Port 1, RS-232 for ports 2-4
Max connection:	1
Remote IP Address:	255.255.255.255
Dipswitch settings:	Run

13. IP SERIAL SERVER LCD PANEL CONFIGURATION

This chapter describe the configuration through LCD panel. The LCD panel is a two-line display and is operated through 4 buttons, “MENU”, “UP”, “DOWN”, and “ENTER” buttons.

When the server is first powered on, the display is shown as below:

IP serial server
4 PORT

13.1 Basic Operations of the Buttons

The LCD menu options are organized as a 4-level tree structure, and through the buttons, users can traverse the tree to view or change the settings for options.

Menu

It moves up or down one level in the option tree.

UP

1. moves to the previous option within same level, or
 2. increases digit where cursor's at if it's a configurable option like IP address or,
 3. goes through the possible settings if it's a configurable option like DHCP, which can be set to either ENABLE or DISABLE.
-

DOWN

1. moves to the next option within same level, or
 2. decreases digit where cursor's at if it's a configurable option like IP address or,
 3. goes through possible settings if it's a configurable option like DHCP, which can be set to either ENABLE or DISABLE.
-

Enter

1. select the option and if it's not at the last level, move down to the option's next level or,
2. move cursor to the right

PROYECTO DE OBRAS	ACTIVIDAD (A)	ACTIVIDAD (B)	ACTIVIDAD (C)
1.000.000.000	1.000.000.000	1.000.000.000	1.000.000.000
	1.000.000.000	1.000.000.000	1.000.000.000
	1.000.000.000	1.000.000.000	1.000.000.000
	1.000.000.000	1.000.000.000	1.000.000.000
2.000.000.000	2.000.000.000	2.000.000.000	2.000.000.000
	2.000.000.000	2.000.000.000	2.000.000.000
	2.000.000.000	2.000.000.000	2.000.000.000
	2.000.000.000	2.000.000.000	2.000.000.000
3.000.000.000	3.000.000.000	3.000.000.000	3.000.000.000
	3.000.000.000	3.000.000.000	3.000.000.000
	3.000.000.000	3.000.000.000	3.000.000.000
	3.000.000.000	3.000.000.000	3.000.000.000
4.000.000.000	4.000.000.000	4.000.000.000	4.000.000.000
	4.000.000.000	4.000.000.000	4.000.000.000
	4.000.000.000	4.000.000.000	4.000.000.000
	4.000.000.000	4.000.000.000	4.000.000.000
5.000.000.000	5.000.000.000	5.000.000.000	5.000.000.000
	5.000.000.000	5.000.000.000	5.000.000.000
	5.000.000.000	5.000.000.000	5.000.000.000
	5.000.000.000	5.000.000.000	5.000.000.000

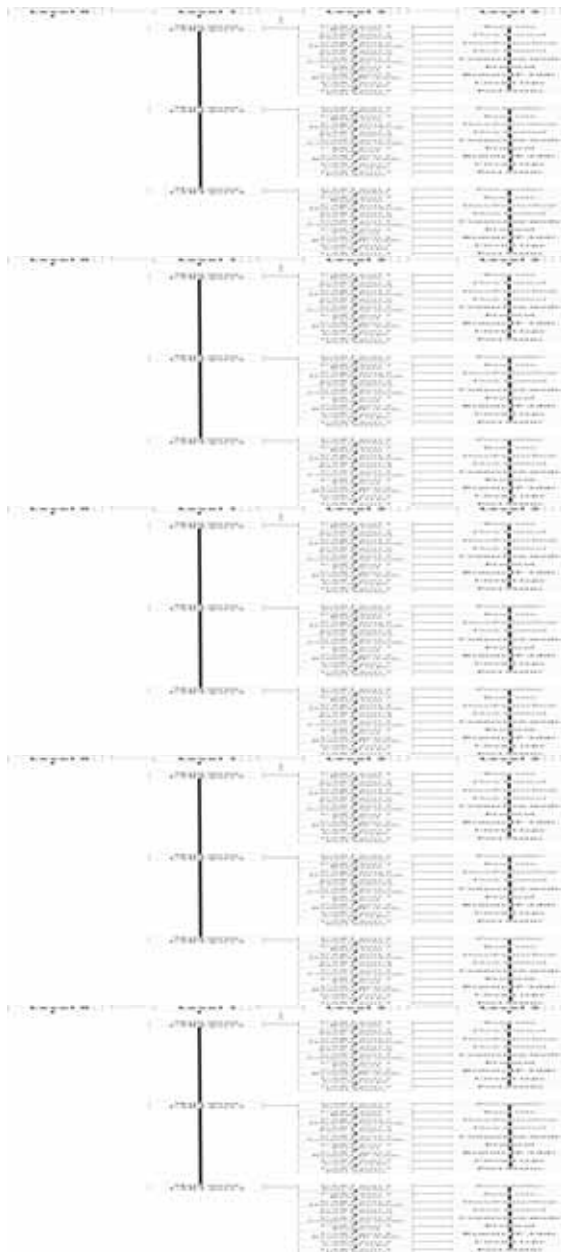

Figure 47 The Tree Structure of LCD Menu

APPENDIX A: RS-232 CONNECTIONS

Serial Server DB-9 Pin-outs in RS-232 Mode

			
RS-232 Signal Name	DTE	RS-232	DB-9M Pin
Carrier Detect	In	DCD	1
Receive Data	In	RXD	2
Transmit Data	Out	TXD	3
Data Terminal Ready	Out	DTR	4
Signal Ground	---	GND	5
Data Set Ready	In	DSR	6
Request To Send	Out	RTS	7
Clear To Send	In	CTS	8
Ring Indicator	In	RI	9

Figure 48 RS-232 Connections in a DB-9 Connector

APPENDIX B: RS-422 CONNECTIONS

Serial Server DB-9 Pin-outs in RS-422 Mode

			
RS-422 Signal Name	Direction	RS-422	DB9M Pin
Receive Data A (-)	In	RXDA (-)	1
Receive Data B (+)	In	RXDB (+)	2
Transmit Data B (+)	Out	TXDB (+)	3
Transmit Data A (-)	Out	TXDA (-)	4
Signal Ground	---	GND	5
Clear to Send A (-)	In	CTSA (-)	6
Clear to Send B (+)	In	CTSB (+)	7
Request to Send B (+)	Out	RTSB (+)	8
Request to Send A (-)	Out	RTSA (-)	9

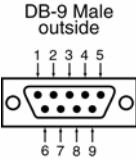
Figure 49 RS-422 Connections in a DB-9 Connector

APPENDIX C: RS-485 CONNECTIONS

Serial Server DB-9 Pin-out in RS-485 Mode

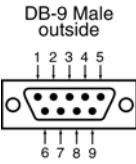
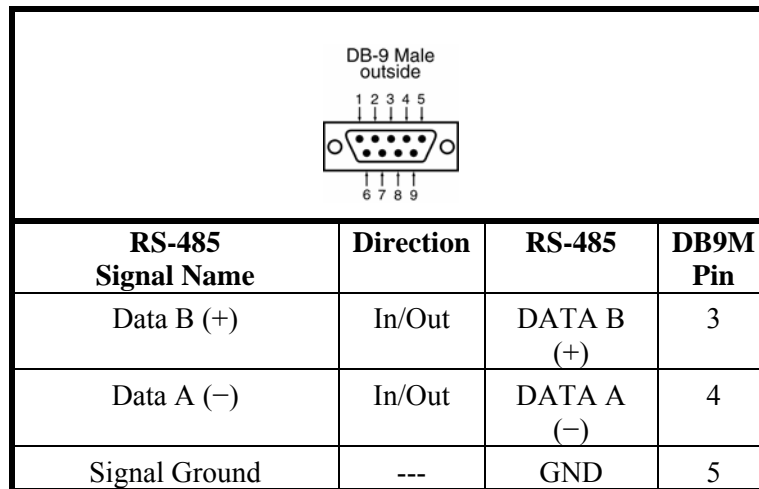

Figure 50 DB-9 Pin-out in RS-485 Mode

Note:

Some RS-485 devices are marked opposite the RS-485 standard, which defines the Data B line as positive relative to Data A during a Mark state before enabling the transmitter, and after transmitting before tri-stating. If an RS-485 device does not respond, try swapping the Data B and Data A lines.

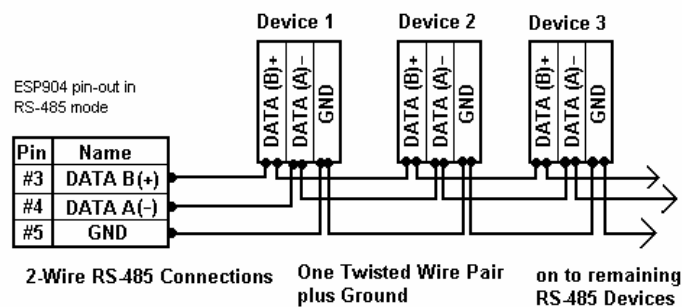
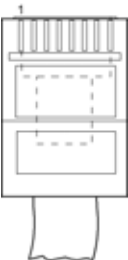

Figure 51 2-wire RS-485 Connection

To connect 4-Wire RS-485 devices, the RS-422 Mode can be used provided the **Serial Server** will be connected as a master in a single master system. If using multiple masters, the **Serial Server** cannot be used, as it does not tri-state the transmitter in RS-422 mode

APPENDIX D: NETWORK CONNECTIONS

Standard Ethernet Cable RJ-45 Pin-out



RJ-45 Pin	Signal	Wire Color	RJ-45 Pin
1	TX+	White-Green	1
2	TX+	Green	2
3	RX+	White-Orange	3
4	Not used	Blue	4
5	Not used	White-Blue	5
6	RX-	Orange	6
7	Not used	White-Brown	7
8	Not used	Brown	8

Figure 52 Pin-out for a Standard Ethernet Cable

Crossover Ethernet Cable RJ-45 Pin-out

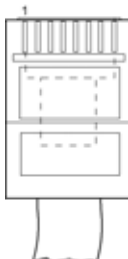

RJ-45 Pin	Signal	Wire Color	RJ-45 Pin
1	TX+	White-Green	3
2	TX+	Green	6
3	RX+	White-Orange	1
4	Not used	Blue	4
5	Not used	White-Blue	5
6	RX-	Orange	2
7	Not used	White-Brown	7
8	Not used	Brown	8

Figure 53 Pin-out for a Crossover Ethernet Cable